

Engineering Data

Aqua thermal



CONTENTS

Part 1 General Information.....	3
Part 2 Engineering Data	11
Part 3 Installation and Field Settings.....	45

Part 1

General Information

1 System introduction	4
2 Product lineup.....	7
3 Nomenclature	7
4 System Design And Unit Selection	7

1 System introduction

1.1 System Schematic

Aqua thermal is an integrated air-to-water space heating and space cooling heat pump system. The outdoor heat pump system extracts heat from the outdoor air and transfers this heat through refrigerant piping to the plate heat exchanger in the hydronic system. The heated water in the hydronic system circulates to low temperature heat emitters (floor heating loops or low temperature radiators) to provide space heating. The 4-way valve in the outdoor unit can reverse the refrigerant cycle so that the hydronic system can provide chilled water for cooling using fan coil units.

The heating capacity of heat pumps decreases with ambient temperature. Aqua thermal is reserved an auxiliary electric heater control port to provide additional heating capacity for use during extremely cold weather when the heat pump capacity is insufficient. The auxiliary electric heater also serves as a backup in case of heat pump malfunction and for anti-freeze protection of the outside water piping in winter.

1.2 Typical Applications

1.2.1 Space Heating Through Floor Heating Loops

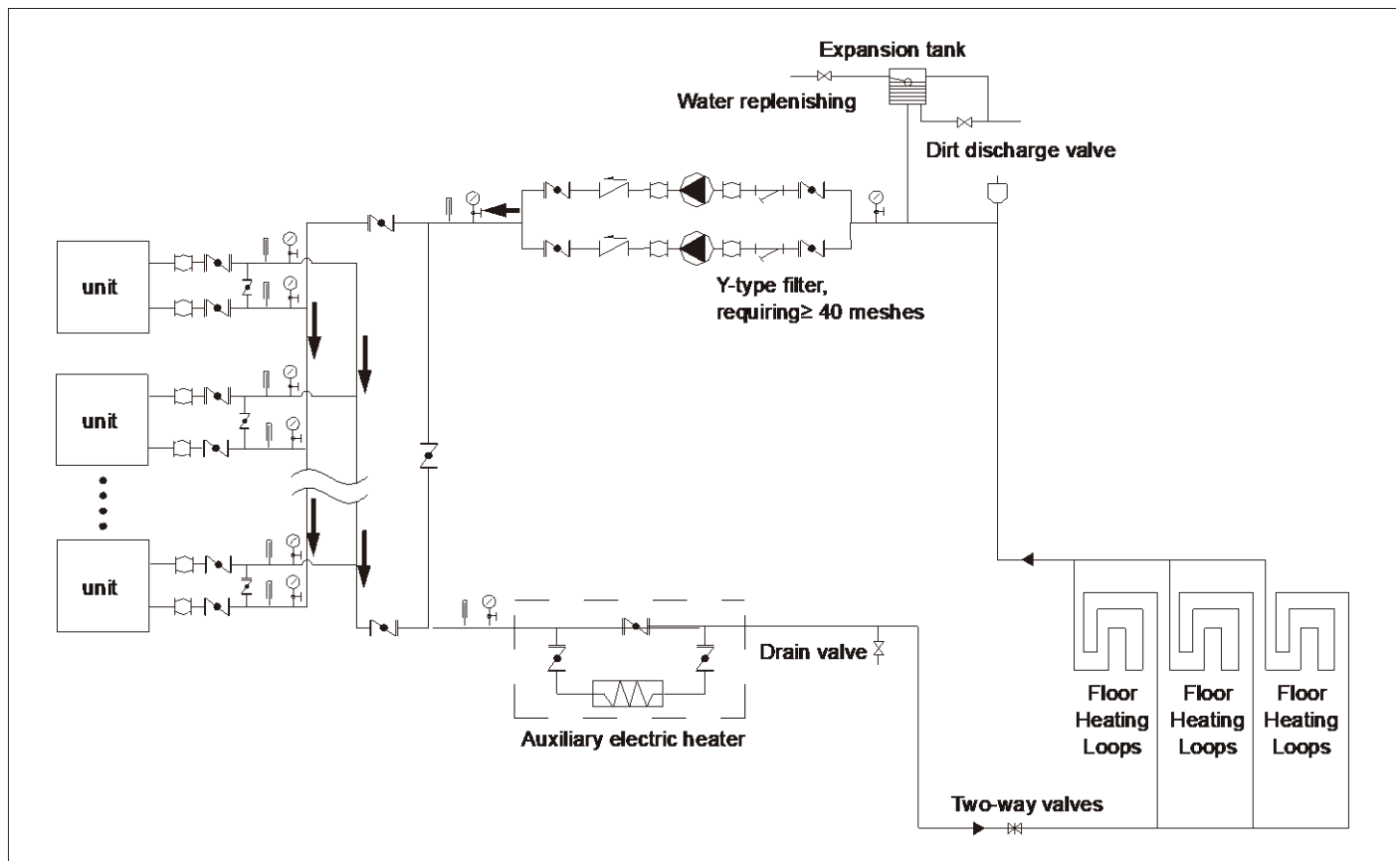

Legend				
Stop valve	Pressure gauge	Flexible joint	Gate valve	Automatic discharge valve
Y-shaped filter	Thermometer	Circulating pump	Check valve	

1.2.2 Space Cooling and Heating through Fan Coil Unit

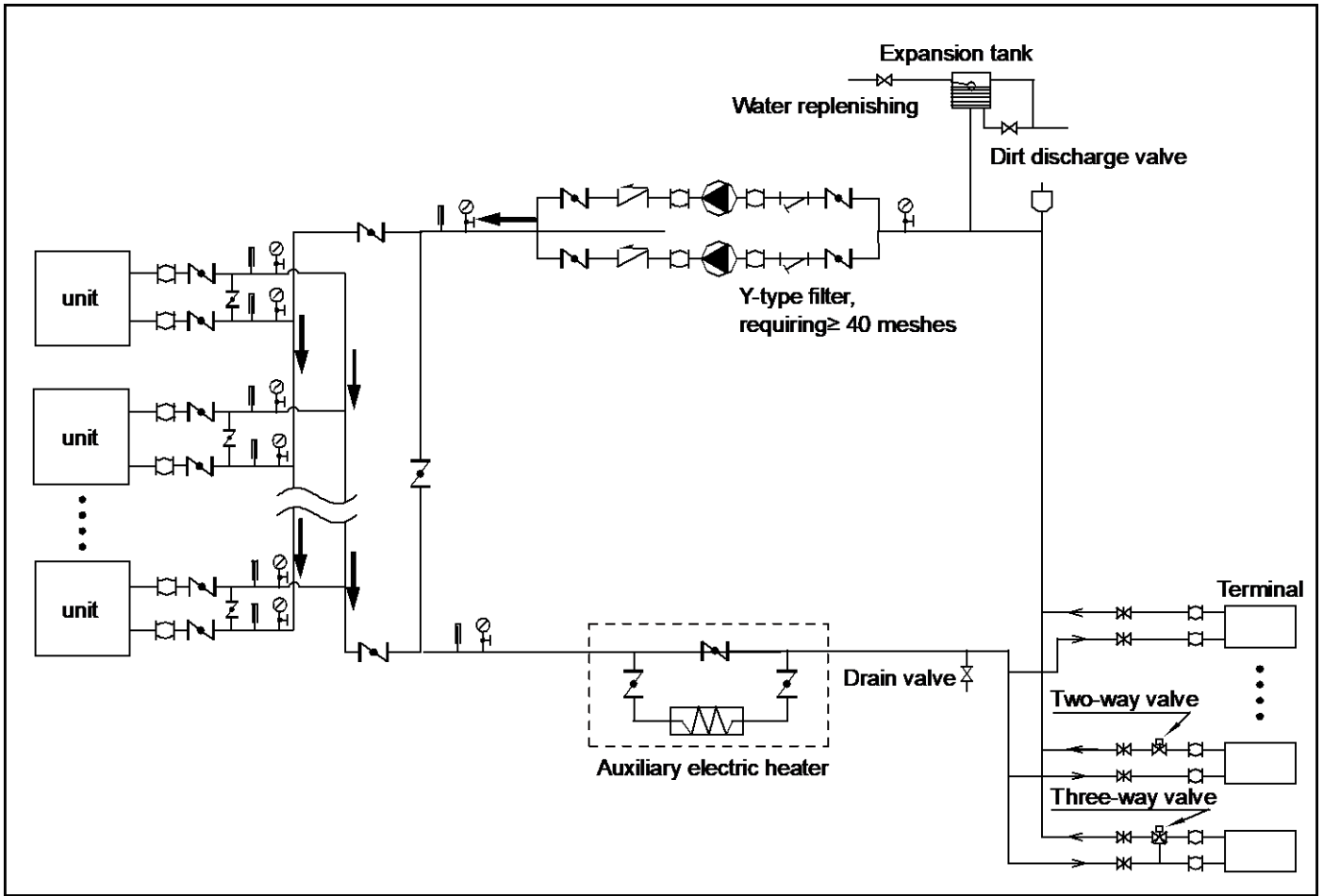

Part 1 - General Information

Legend				
Stop valve	Pressure gauge	Flexible joint	Gate valve	Automatic discharge valve
Y-shaped filter	Thermometer	Circulating pump	Check valve	

1.2.3 Space Heating Through Floor Heating Loops and Space Cooling Through Fan Coil Unit

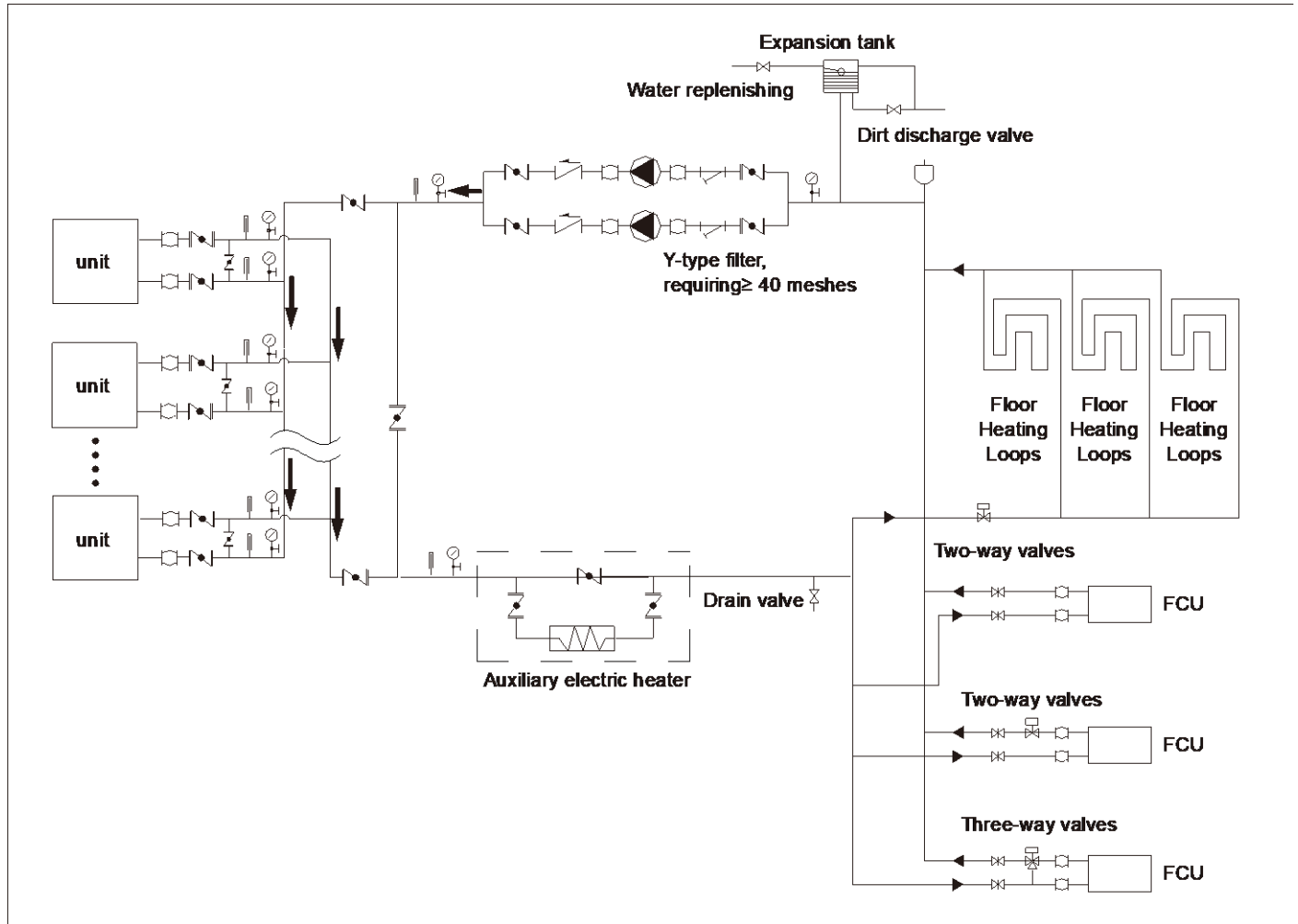



Legend				
Stop valve	Pressure gauge	Flexible joint	Gate valve	Automatic discharge valve
Y-shaped filter	Thermometer	Circulating pump	Check valve	

Note:

In space cooling mode, the 2-way valve on the floor heating branch circuit is closed to prevent cold water entering the floor heating loops.

2 Product lineup

Model	MC-SU75-RN8L-B MC-SU75M-RN8L-B	MC-SU90-RN8L-B MC-SU90M-RN8L-B	MC-SU140-RN8L-B MC-SU140M-RN8L-B	MC-SU180-RN8L-B MC-SU180M-RN8L-B
Power supply	380-415V/3Ph/50Hz	380-415V/3Ph/50Hz	380-415V/3Ph/50Hz	380-415V/3Ph/50Hz
Appearance				

3 Nomenclature

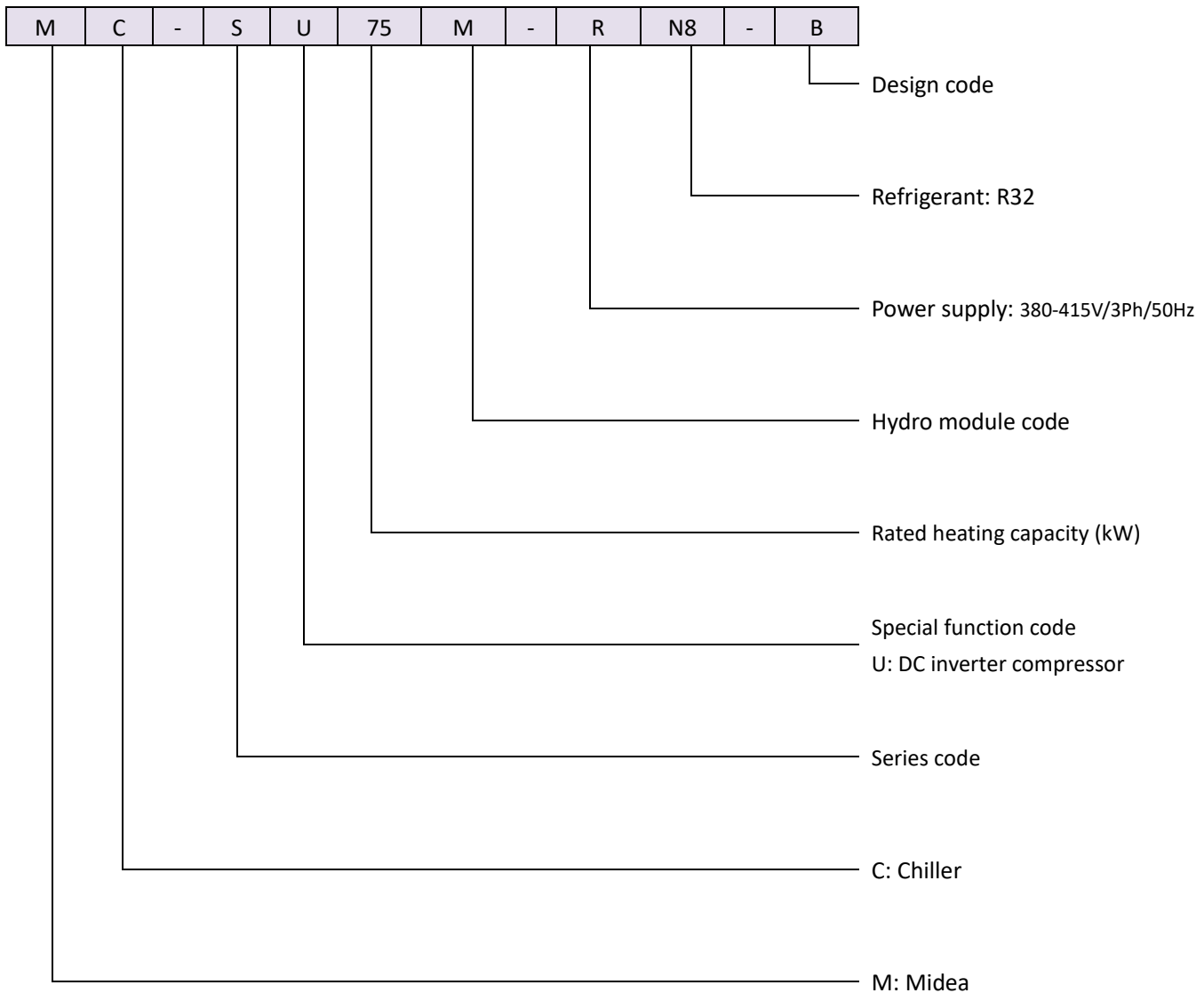

4 System Design and Unit Selection

4.1 Selection Procedure

Step 1: Total heat load calculation

Calculate conditioned surface area
 Select the heat emitters (type, quantity, water temperature and heat load)

Step 2: System configuration

Decide whether to enable or disable auxiliary electric heater

Step 3: Selection of outdoor units

Determine required total heat load on outdoor units
 Set capacity safety factor
 Select power supply

Provisionally select Aqua thermal Series unit capacity¹ based on nominal capacity

Correct capacity of the outdoor units for the following items:
 Outdoor air temperature / Outdoor humidity / Water outlet temperature² /
 Altitude / Anti-freeze type

Is corrected Aqua thermal capacity \geq Required total heat load on outdoor units³

Yes
 Aqua thermal system selection is complete

No
 Select a larger model or enable auxiliary electric heater operation

Notes:

- Up to 16 units (8 units for MC-SU180-RN8L-B) can be connected together, giving a system cooling/heating capacity range from 75kW to 2240kW.
- If the required water temperatures of the heat emitters are not all the same, the Aqua thermal's outlet water temperature setting should be set at the highest of the heat emitter required water temperatures. If the water outlet design temperature falls between two temperatures listed in the outdoor unit's capacity table, calculate the corrected capacity by interpolation.
- Select Aqua thermal which satisfies both total heating and cooling load requirements.

4.2 Modular Chiller Leaving Water Temperature (LWT) Selection

The recommended design LWT ranges for different types of heat emitter are:

- For floor heating: 30 to 35°C
- For fan coil units: 30 to 45°C
- For low temperature radiators: 40 to 50°C

4.3 Optimizing System Design

To get the most comfort with the lowest energy consumption with Aqua thermal, it is important to take account of the following considerations:

- Choose heat emitters that allow the heat pump system to operate at as low a hot water temperature as possible whilst still providing sufficient heating.

Part 2

Engineering Data

1 Specifications	12
2 Electrical Characteristics.....	14
3 Dimensions and Center of Gravity	15
4 Operating Limits.....	17
5 Capacity Tables.....	18
6 Performance Adjustment Factors	34
7 Hydronic Performance.....	36
8 Octave Band Levels	40

1 Specifications

Model name			MC-SU75-RN8L-B	MC-SU90-RN8L-B	MC-SU140-RN8L-B	MC-SU180-RN8L-B	
Power supply		V/Ph/Hz	380~415/3/50	380~415/3/50	380~415/3/50	380~415/3/50	
Cooling ¹	Capacity	kW	70	82	130	164	
	Rated input	kW	26.8	27.8	50.5	56	
	EER			2.61	2.95	2.57	2.93
Heating ²	Capacity	kW	75	90	138	180	
	Rated input	kW	23.7	28.1	44.5	57	
	COP			3.16	3.2	3.1	3.16
Air side heat exchanger	Type		Finned tube	Finned tube	Finned tube	Finned tube	
	Fan motor type		DC motor	DC motor	DC motor	DC motor	
	Fan motor output	W	920	920	1500	920	
	Fan motor quantity			2	2	2	4
	Air flow rate	m ³ /h	28500	35000	50000	70000	
Water side heat exchanger	Type		Plate	Plate	Plate	Plate	
	Volume	L	5.17	7.05	11.1	6.96×2	
	Rated water flow	m ³ /h	12.04	15	22.36	28.2	
	Water flow range	m ³ /h	8.0~15.5	10.2 ~ 18	15.6~28.5	20~36.1	
	Water pressure drop	kPa	65	75	65	96	
Refrigerant system	Refrigerant type		R32	R32	R32	R32	
	Refrigerant charge ³	kg	9	16 (11.5+4.5)	15.5(11.5+4)	16 (5.5+10.5)*2	
	Throttle type		EXV	EXV	EXV	EXV	
Sound power level ⁴		dB	86	83	92	92	
Sound pressure level(1m) ⁵		dB(A)	69	65	73	72	
Net dimensions (W×H×D)		mm	2000×1770×960	2220×2315×1135	2220×2300×1135	2752×2413×2220	
Packed dimensions (W×H×D)		mm	2085×1890×1030	2250×2445×1180	2250×2425×1180	2810×2446×2245	
Net/Gross weight		kg	440/455	635/660	670/690	1400/1420	
Water pipe connections		mm	DN50	DN50	DN65	DN80	
Water pressure range		MPa	0.05 ~ 1.0	0.05 ~ 1.0	0.05 ~ 1.0	0.05 ~ 1.0	
Water flow switch action flow		m ³ /h	8	10	15.6	20	
Vent Valve max working pressure		Mpa	1	1	1	1	
Safety valve action pressure		Mpa	0.6	0.6	0.6	0.6	
Controller			KJRM-120H2/BMWK	KJRM-120H2/BMWK	KJRM-120H2/BMWK	KJRM-120H2/BMWK	
Operating temperature	Cooling	°C	-10 to 48	-10 to 48	-10 to 48	-10 to 48	
	Heating	°C	-20 to 43	-20 to 43	-20 to 43	-20 to 43	
Water outlet temperature	Cooling	°C	0 to 20	0 to 20	0 to 20	0 to 20	
	Heating	°C	25 to 54	25 to 54	25 to 54	25 to 54	

Model name			MC-SU75M-RN8L-B	MC-SU90M-RN8L-B	MC-SU140M-RN8L-B	MC-SU180M-RN8L-B
Power supply		V/Ph/Hz	380~415/3/50	380~415/3/50	380~415/3/50	380~415/3/50
Cooling ¹	Capacity	kW	69.7	82	129.5	163.0
	Rated input	kW	27.3	28.3	51.4	57.7
	EER			2.55	2.90	2.52
Heating ²	Capacity	kW	75.4	90	138.6	181.2
	Rated input	kW	24.3	29	45.6	59.1
	COP			3.10	3.10	3.04
Air side heat exchanger	Type		Finned tube	Finned tube	Finned tube	Finned tube
	Fan motor type		DC motor	DC motor	DC motor	DC motor
	Fan motor output	W	920	920	1500	920
	Fan motor quantity		2	2	2	4
	Air flow rate	m ³ /h	28500	35000	50000	70000
Water side heat exchanger	Type		Plate	Plate	Plate	Plate
	Volume	L	5.17	7.05	11.1	6.96×2
	Rated water flow	m ³ /h	12.04	15	22.36	28.2
	Water flow range	m ³ /h	8.0~15.5	10.2 ~ 18	15.6~28.5	20~36.1
Refrigerant system	Refrigerant type		R32	R32	R32	R32
	Refrigerant charge ³	kg	9	16 (11.5+4.5)	15.5(11.5+4)	16 (5.5+10.5)*2
	Throttle type		EXV	EXV	EXV	EXV
Pump	Power supply	V/Ph/Hz	380~415/3/50	380~415/3/50	380~415/3/50	380~415/3/50
	Rated input	kW	1.5	1.5	2.2	1.5
	Rated current	A	3.15	3.15	4.45	3.15
Expansion tank	Volume	L	0.15	0.15	0.15	0.15
	Precharge pressure	Mpa	1.0	1.0	1.0	1.0
	Test pressure	Mpa	12	12	24	12
Sound power level ⁴		dB	86	83	93	92
Sound pressure level(1m) ⁵		dB(A)	69	65	74	72
Net dimensions (W×H×D)		mm	2000×1770×960	2220×2315×1135	2220×2300×1135	2752×2413×2220
Packed dimensions (W×H×D)		mm	2085×1890×1030	2250×2445×1180	2250×2425×1180	2810×2446×2245
Net/Gross weight		kg	475/490	686/711	746/767	1500/1504
Water pipe connections		mm	DN50	DN50	DN65	DN80
Water pressure range		MPa	0.05 ~ 1.0	0.05 ~ 1.0	0.05 ~ 1.0	0.05 ~ 1.0
Water flow switch action flow		m ³ /h	8	10	15.6	20
Vent Valve max working pressure		Mpa	1	1	1	1
Safety valve action pressure		Mpa	0.6	0.6	0.6	0.6
Controller			KJRM-120H2/BMWK	KJRM-120H2/BMWK	KJRM-120H2/BMWK	KJRM-120H2/BMWK
Operating temperature	Cooling	°C	-10 to 48	-10 to 48	-10 to 48	-10 to 48
	Heating	°C	-20 to 43	-20 to 43	-20 to 43	-20 to 43
Water outlet temperature	Cooling	°C	0 to 20	0 to 20	0 to 20	0 to 20
	Heating	°C	25 to 54	25 to 54	25 to 54	25 to 54

Notes:

1. Outdoor ambient temperature 35°C DB. EWT 12°C, LWT 7°C;
2. Outdoor ambient temperature 7°C DB/6°C WB. EWT 40°C, LWT 45°C;
3. The total amount of refrigerant for unit which capacity above 90kW include (factory charged + field charged).
4. Test standard: EN12102-1. Outdoor ambient temperature 35°C DB. EWT 12°C, LWT 7°C
5. Outdoor ambient temperature 35°C DB. EWT 12°C, LWT 7°C

Sound pressure level is the test average measured in a semi-anechoic chamber. The test position is 1m right in front of the unit for four sides and $(1+H)/2m$ (where H is the height of the unit) above the floor. During in-situ operation, sound pressure levels may be higher as a result of ambient noise.

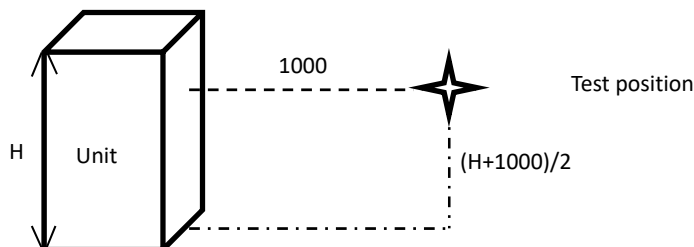

6. Capacity and efficiency data calculated in accordance with EN14511; EN14825
7. Seasonal space heating energy efficiency class tested in average climate conditions.

2 Electrical Characteristics

System	Outdoor unit				Power current		Compressor		Fan	
	Voltage	Hz	Min.	Max.	MCA	MOP	MSC	RLA	kW	FLA
	(V)		(V)	(V)	(A)	(A)	(A)	(A)		(A)
MC-SU75-RN8L-B	380-415	50	342	456	46	54	-	34.09	0.92	4.4
MC-SU75M-RN8L-B	380-415	50	342	456	49	57		34.09	0.92	4.4
MC-SU90-RN8L-B	380-415	50	342	456	60	70	-	60.00	0.92	5.2
MC-SU90M-RN8L-B	380-415	50	342	456	63	73		60.00	0.92	5.2
MC-SU140-RN8L-B	380-415	50	342	456	90	106	-	34.09	1.5	8
MC-SU140M-RN8L-B	380-415	50	342	456	94	110		34.09	1.5	8
MC-SU180-RN8L-B	380-415	50	342	456	120	141	-	30.86	0.92	5.2
MC-SU180M-RN8L-B	380-415	50	342	456	126	147		30.86	0.92	5.2

Note:

MCA: Min. Circuit Amps. (A)

MOP: Maximum overcurrent protector (A)

MSC : Max. Starting Amps. (A)

RLA: In nominal cooling or heating test condition, the input Amps of compressor where MAX. Hz can operate Rated Load Amps. (A)

KW: Rated Motor Output

FLA: Full Load Amps. (A)

3 Dimensions and Center of Gravity

MC-SU75-RN8L-B, MC-SU75M-RN8L-B

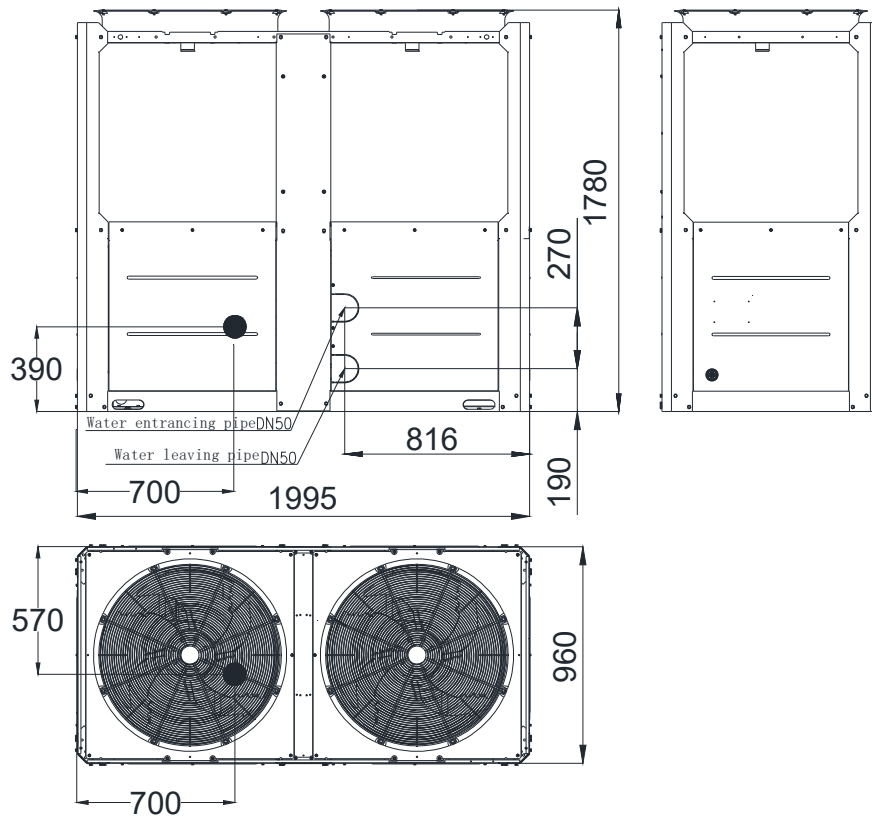

MC-SU90-RN8L-B, MC-SU90M-RN8L-B

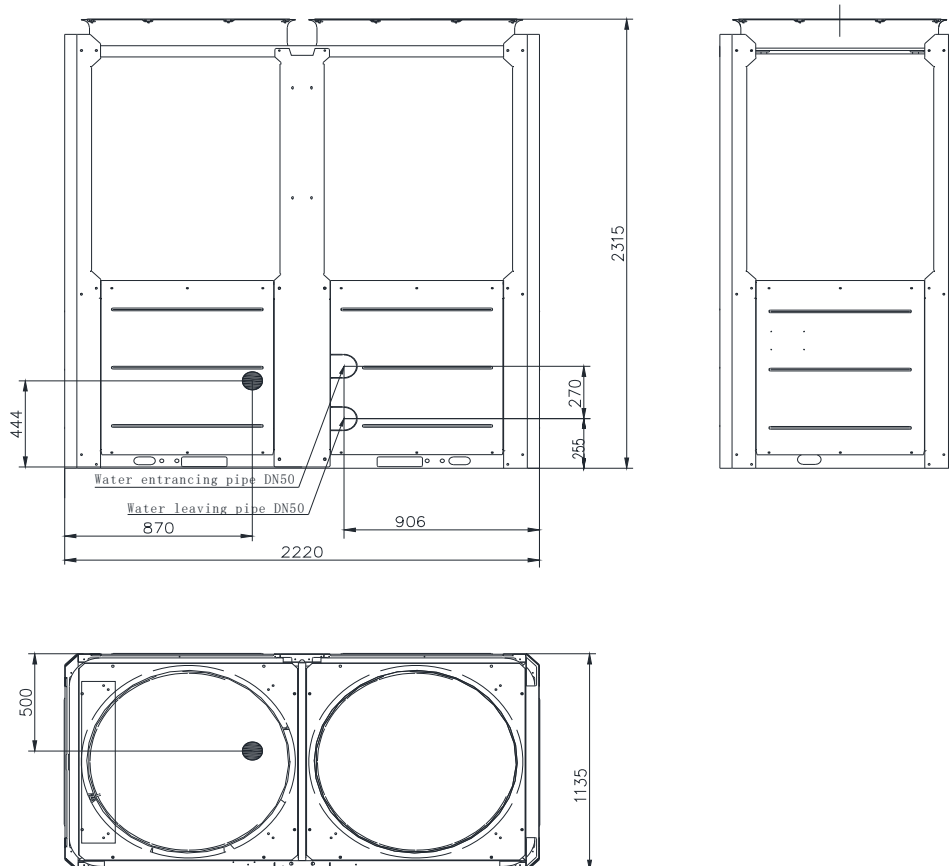

Aqua thermal



MC-SU140-RN8L-B, MC-SU140M-RN8L-B

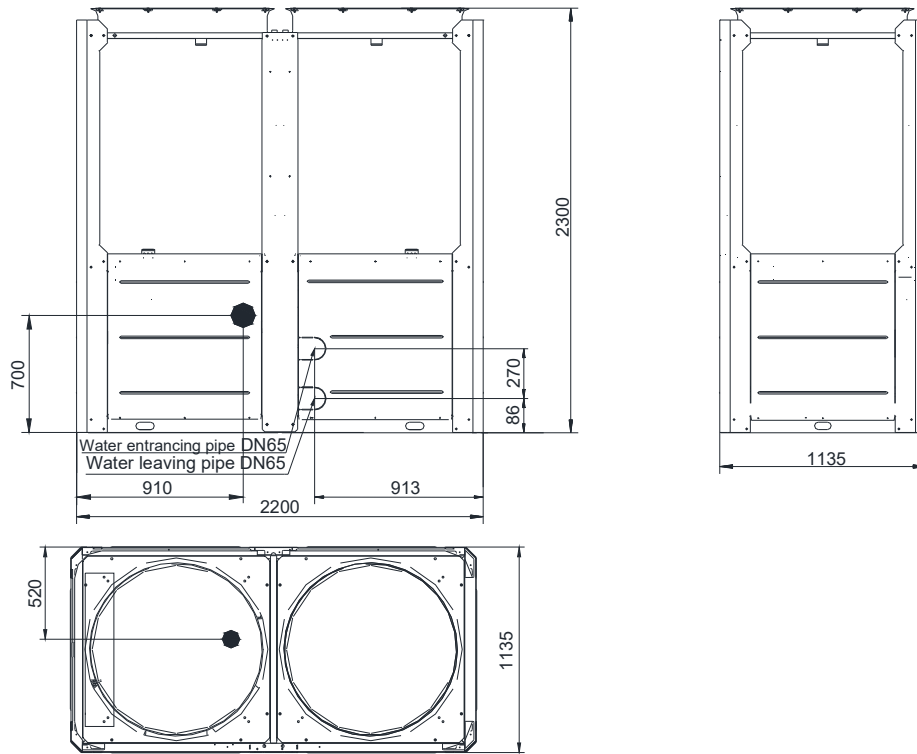

MC-SU180-RN8L-B, MC-SU180M-RN8L-B

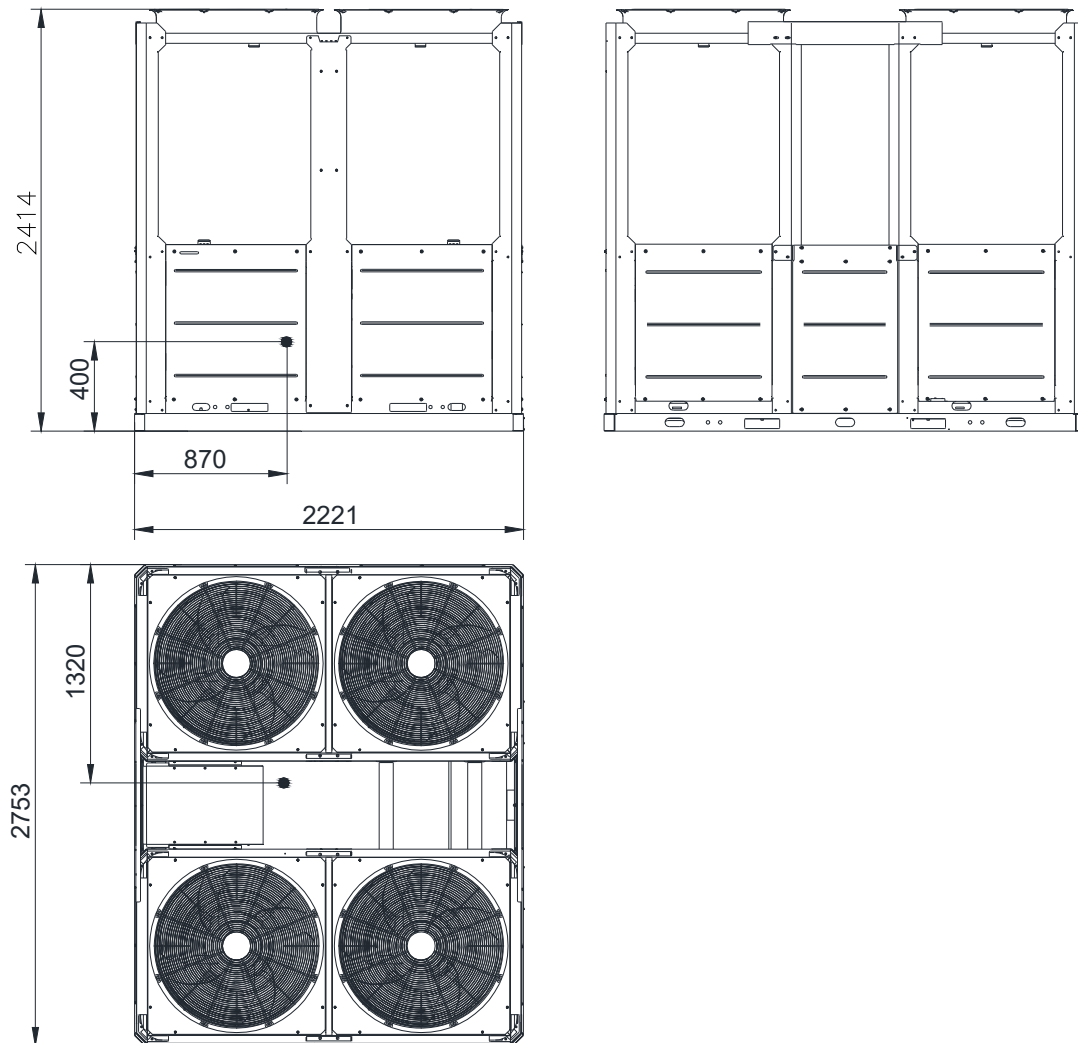

4 Operating Limits

T4: Ambient temperature(°C)

Two: Leaving water temperature(°C)

4.1 Cooling operating range

MC-SU75-RN8L-B, MC-SU90-RN8L-B, MC-SU140-RN8L-B, MC-SU180-RN8L-B
 MC-SU75M-RN8L-B, MC-SU90M-RN8L-B, MC-SU140M-RN8L-B, MC-SU180M-RN8L-B

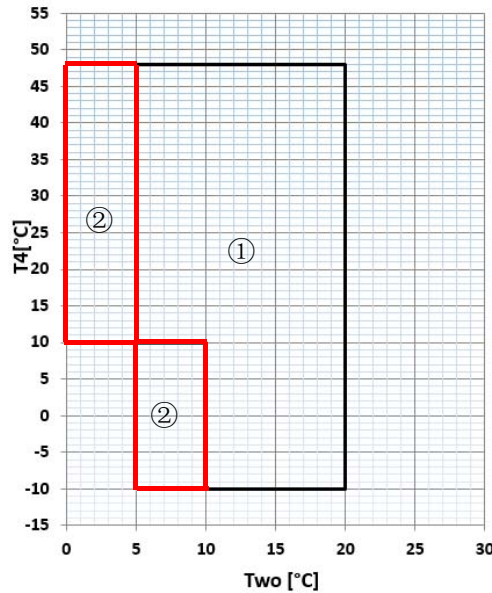

Notes:

- ① Normal mode
- ② Low leaving water temperature mode

Low leaving water temperature mode can be set through wired controller, please refer to the Operation Manual for details. If low leaving water temperature function is effective, the operation range will extend to the red frame above. When the set temperature is less than 5°C, antifreeze liquid (concentration above 15%) should be added in the water system, otherwise the unit will be damaged.

4.2 Heating operating range

MC-SU75-RN8L-B, MC-SU75M-RN8L-B
 MC-SU140-RN8L-B, MC-SU140M-RN8L-B

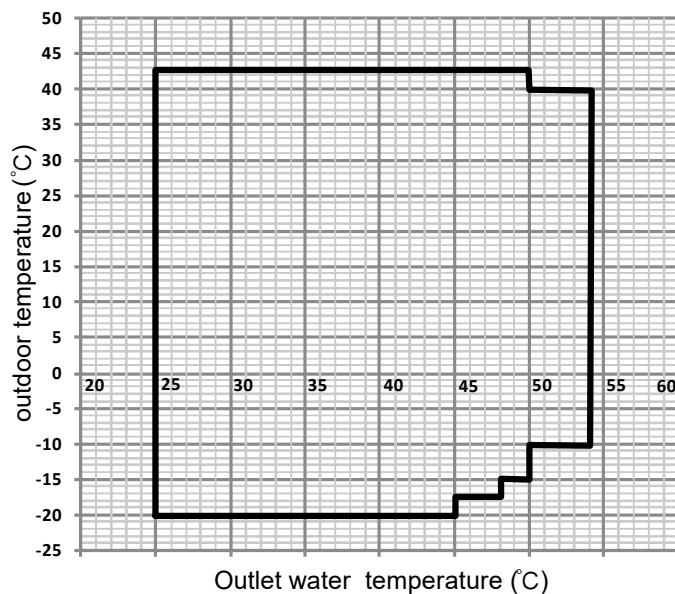

MC-SU90-RN8L-B, MC-SU90M-RN8L-B
 MC-SU180-RN8L-B, MC-SU180M-RN8L-B

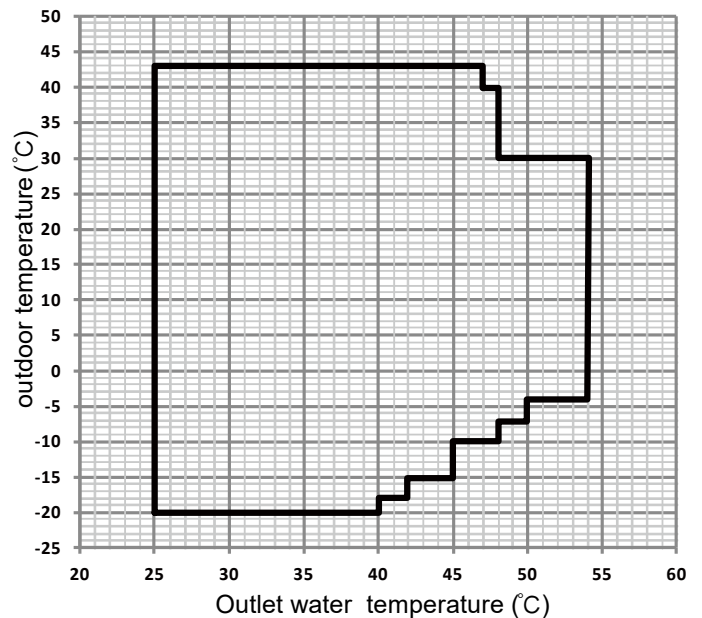

5 Capacity Tables

5.1 Heating Capacity Tables

MC-SU75-RN8L-B

LWT	DB																	
	-20			-18			-15			-10			-5			0		
	HC	PI	COP	HC	PI	COP	HC	PI	COP	HC	PI	COP	HC	PI	COP	HC	PI	COP
25	30.9	13.2	2.3	41.3	15.3	2.7	42.2	15.4	2.7	43.2	15.5	2.8	45.7	15.5	2.9	49.5	15.8	3.1
30	31.2	15.2	2.1	40.8	15.9	2.6	42.1	16.0	2.6	43.3	16.1	2.7	45.9	16.3	2.8	48.6	16.5	2.9
35	30.2	16.1	1.9	39.2	17.3	2.3	40.3	17.4	2.3	41.4	17.5	2.4	46.7	18.7	2.5	47.8	17.3	2.8
40	23.7	14.1	1.7	35.7	19.4	1.8	37.2	19.6	1.9	38.7	19.8	2.0	44.6	20.4	2.2	46.1	18.4	2.5
45	18.8	13.2	1.4	32.8	20.2	1.6	34.5	20.4	1.7	36.3	20.6	1.8	40.4	21.0	1.9	44.5	19.5	2.3
48				25.6	19.8	1.3	29.1	20.2	1.4	32.6	20.4	1.6	37.8	21.0	1.8	42.6	20.1	2.1
50							28.8	20.1	1.4	29.7	19.5	1.5	35.2	20.9	1.7	40.8	20.7	2.0
54										23.9	16.3	1.5	28.4	17.5	1.6	32.9	17.4	1.9

LWT	DB																	
	5			7			10			15			20			25		
	HC	PI	COP	HC	PI	COP	HC	PI	COP	HC	PI	COP	HC	PI	COP	HC	PI	COP
25	54.1	16.4	3.3	82.2	23.2	3.5	83.6	20.8	4.0	96.9	23.2	4.2	100.3	22.8	4.4	106.2	22.8	4.6
30	53.2	16.9	3.2	80.7	22.9	3.5	82.2	21.5	3.8	91.4	22.5	4.1	96.5	22.6	4.3	104.7	23.1	4.5
35	55.1	18.3	3.0	74.7	21.3	3.5	76.9	21.0	3.7	88.2	22.4	3.9	93.4	22.5	4.1	102.5	22.8	4.5
40	55.7	19.6	2.8	74.9	23.3	3.2	77.8	22.9	3.4	85.7	23.5	3.7	87.4	22.0	4.0	96.1	22.4	4.3
45	56.4	21.0	2.7	75.0	23.7	3.2	76.2	23.5	3.2	79.0	23.1	3.4	85.2	23.0	3.7	93.4	23.5	4.0
48	56.2	21.4	2.6	66.2	23.0	2.9	70.2	23.2	3.0	51.0	15.6	3.3	79.9	22.0	3.6	86.2	22.7	3.8
50	56.1	21.9	2.6	65.0	23.1	2.8	68.0	22.9	3.0	38.4	12.3	3.1	76.2	21.5	3.6	79.4	21.5	3.7
54	45.2	18.3	2.5	63.8	23.0	2.8	68.0	23.2	2.9	18.6	6.2	3.0	22.6	7.3	3.1	23.5	7.5	3.2

LWT	DB											
	30			35			40			43		
	HC	PI	COP	HC	PI	COP	HC	PI	COP	HC	PI	COP
25	113.6	21.6	5.2	114.4	19.4	5.9	115.9	18.6	6.2	114.3	17.7	6.5
30	115.4	23.0	5.0	118.6	20.8	5.7	123.3	21.1	5.9	117.1	19.6	6.0
35	114.2	23.7	4.8	121.5	22.9	5.3	126.2	23.3	5.4	118.6	21.0	5.6
40	105.7	23.9	4.4	112.5	22.5	5.0	117.9	23.0	5.1	110.3	20.8	5.3
45	95.4	22.6	4.2	102.8	21.6	4.8	105.4	21.7	4.9	99.3	19.8	5.0
48	70.8	17.5	4.0	74.7	16.5	4.5	77.8	16.8	4.6	71.7	15.1	4.8
50	56.7	14.4	3.9	59.1	14.0	4.2	63.4	14.6	4.4	57.8	12.7	4.6
54	25.4	7.8	3.3	28.5	8.4	3.4	40.2	11.5	3.5			

Abbreviations:

HC: Total heating capacity (kW)

PI: Power input (kW)

LWT: Leaving water temperature (°C)

DB: Dry-bulb temperature for outdoor air temperature (°C)

Performance specifications measured with water pump operating at rated water flow rate.

MC-SU75M-RN8L-B

LWT	DB																	
	-20			-18			-15			-10			-5			0		
	HC	PI	COP	HC	PI	COP	HC	PI	COP	HC	PI	COP	HC	PI	COP	HC	PI	COP
25	30.9	14.7	2.1	41.3	16.8	2.5	42.2	16.9	2.5	43.2	17.0	2.5	45.7	17.0	2.7	49.5	17.3	2.9
30	31.2	16.7	1.9	40.8	17.4	2.3	42.1	17.5	2.4	43.3	17.6	2.5	45.9	17.8	2.6	48.6	18.0	2.7
35	30.2	17.6	1.7	39.2	18.8	2.1	40.3	18.9	2.1	41.4	19.0	2.2	46.7	20.2	2.3	47.8	18.8	2.5
40	23.7	15.6	1.5	35.7	20.9	1.7	37.2	21.1	1.8	38.7	21.3	1.8	44.6	21.9	2.0	46.1	19.9	2.3
45	18.8	14.7	1.3	32.8	21.7	1.5	34.5	21.9	1.6	36.3	22.1	1.6	40.4	22.5	1.8	44.5	21.0	2.1
48				25.6	21.3	1.2	29.1	21.7	1.3	32.6	21.9	1.5	37.8	22.5	1.7	42.6	21.6	2.0
50							28.8	21.6	1.3	29.7	21.0	1.4	35.2	22.4	1.6	40.8	22.2	1.8
54										23.9	17.8	1.3	28.4	19.0	1.5	32.9	18.9	1.7

LWT	DB																	
	5			7			10			15			20			25		
	HC	PI	COP	HC	PI	COP	HC	PI	COP	HC	PI	COP	HC	PI	COP	HC	PI	COP
25	54.1	17.9	3.0	82.2	24.7	3.3	83.6	22.3	3.7	96.9	24.7	3.9	100.3	24.3	4.1	106.2	24.3	4.4
30	53.2	18.4	2.9	80.7	24.4	3.3	82.2	23.0	3.6	91.4	24.0	3.8	96.5	24.1	4.0	104.7	24.6	4.3
35	55.1	19.8	2.8	74.7	22.8	3.3	76.9	22.5	3.4	88.2	23.9	3.7	93.4	24.0	3.9	102.5	24.3	4.2
40	55.7	21.1	2.6	74.9	24.8	3.0	77.8	24.4	3.2	85.7	25.0	3.4	87.4	23.5	3.7	96.1	23.9	4.0
45	56.4	22.5	2.5	75.0	25.2	3.0	76.2	25.0	3.0	79.0	24.6	3.2	85.2	24.5	3.5	93.4	25.0	3.7
48	56.2	22.9	2.5	66.2	24.5	2.7	70.2	24.7	2.8	51.0	17.1	3.0	79.9	23.5	3.4	86.2	24.2	3.6
50	56.1	23.4	2.4	65.0	24.6	2.6	68.0	24.4	2.8	38.4	13.8	2.8	76.2	23.0	3.3	79.4	23.0	3.5
54	45.2	19.8	2.3	63.8	24.5	2.6	68.0	24.7	2.8	18.6	7.7	2.4	22.6	8.8	2.6	23.5	9.0	2.6

LWT	DB											
	30			35			40			43		
	HC	PI	COP	HC	PI	COP	HC	PI	COP	HC	PI	COP
25	113.6	23.1	4.9	114.4	20.9	5.5	115.9	20.1	5.8	114.3	19.2	6.0
30	115.4	24.5	4.7	118.6	22.3	5.3	123.3	22.6	5.5	117.1	21.1	5.5
35	114.2	25.2	4.5	121.5	24.4	5.0	126.2	24.8	5.1	118.6	22.5	5.3
40	105.7	25.4	4.2	112.5	24.0	4.7	117.9	24.5	4.8	110.3	22.3	4.9
45	95.4	24.1	4.0	102.8	23.1	4.5	105.4	23.2	4.5	99.3	21.3	4.7
48	70.8	19	3.7	74.7	18.0	4.2	77.8	18.3	4.3	71.7	16.6	4.3
50	56.7	15.9	3.6	59.1	15.5	3.8	63.4	16.1	3.9	57.8	14.2	4.1
54	25.4	9.3	2.7	28.5	9.9	2.9	40.2	13.0	3.1			

Abbreviations:

HC: Total heating capacity (kW)

PI: Power input (kW)

LWT: Leaving water temperature (°C)

DB: Dry-bulb temperature for outdoor air temperature (°C)

Performance specifications measured with water pump operating at rated water flow rate.

Aqua thermal



MC-SU90-RN8L-B

LWT	DB																	
	-20			-18			-15			-10			-7			4		
	HC	PI	COP	HC	PI	COP	HC	PI	COP	HC	PI	COP	HC	PI	COP	HC	PI	COP
25	44.7	21.1	2.1	49.6	21.8	2.3	56.8	22.8	2.5	67.4	23.2	2.9	73.7	23.5	3.1	79.1	24.3	3.3
30	43.9	21.7	2.0	48.7	22.4	2.2	55.8	23.4	2.4	66.2	23.9	2.8	72.4	24.2	3.0	77.7	25.0	3.1
35	42.7	24.8	1.7	47.0	25.3	1.9	53.6	25.9	2.1	63.9	26.1	2.5	70.2	26.2	2.7	75.5	26.3	2.9
40	39.7	26.6	1.5	44.2	27.0	1.6	51.0	27.6	1.8	61.6	28.2	2.2	68.0	28.6	2.4	73.7	28.7	2.6
42				42.4	26.7	1.6	48.9	27.3	1.8	59.9	28.6	2.1	66.5	29.4	2.3	72.2	29.5	2.4
45							45.8	26.9	1.7	57.2	29.2	2.0	64.1	30.6	2.1	69.9	30.8	2.3
47										50.6	27.1	1.9	56.6	28.4	2.0	63.6	29.3	2.2
48										48.6	27.7	1.8	54.5	29.0	1.9	61.2	29.9	2.0
50													48.0	28.0	1.7	55.3	29.3	1.9
54																47.5	29.6	1.6

LWT	DB																	
	2			7			15			20			25			30		
	HC	PI	COP	HC	PI	COP	HC	PI	COP	HC	PI	COP	HC	PI	COP	HC	PI	COP
25	89.9	25.9	3.5	102.0	23.8	4.3	104.8	23.1	4.5	104.9	21.7	4.8	102.8	20.0	5.2	100.0	17.6	5.7
30	88.3	26.6	3.3	101.4	24.5	4.1	103.9	23.7	4.4	104.0	22.3	4.7	101.9	20.5	5.0	99.2	18.1	5.5
35	86.3	26.4	3.3	100.2	26.4	3.8	102.4	24.9	4.1	102.3	23.5	4.3	100.2	20.7	4.8	96.0	18.3	5.2
40	84.9	28.8	2.9	95.7	27.0	3.5	99.1	25.8	3.8	99.6	24.5	4.1	99.3	21.5	4.6	94.6	18.7	5.1
42	83.5	29.8	2.8	92.8	27.5	3.4	98.5	26.8	3.7	98.9	25.0	4.0	98.3	21.8	4.5	90.7	18.8	4.8
45	81.5	31.3	2.6	90.4	28.8	3.1	97.7	28.2	3.5	98.2	25.5	3.9	96.8	22.3	4.3	84.9	18.8	4.5
47	77.6	31.1	2.5	86.5	31.2	2.8	93.5	27.1	3.5	90.1	22.8	3.9	83.7	19.4	4.3	74.6	17.4	4.3
48	74.6	31.8	2.3	83.2	31.9	2.6	89.9	27.6	3.3	86.6	23.3	3.7	80.5	19.8	4.1	71.8	17.8	4.0
50	70.0	32.1	2.2	78.3	32.2	2.4	84.7	27.2	3.1	79.1	22.2	3.6	75.6	19.2	3.9	63.0	17.1	3.7
54	59.9	33.3	1.8	67.0	34.0	2.0	73.9	27.0	2.7	70.2	21.2	3.3	58.9	15.7	3.8	47.0	14.4	3.3

LWT	DB								
	35			40			43		
	HC	PI	COP	HC	PI	COP	HC	PI	COP
25	93.6	15.0	6.3	89.6	13.6	6.6	88.8	13.5	6.6
30	92.8	15.4	6.0	88.9	14.0	6.3	88.0	13.8	6.4
35	89.0	16.7	5.3	80.0	13.3	6.0	78.6	12.4	6.4
40	85.0	16.0	5.3	71.4	11.4	6.3	70.1	10.7	6.5
42	81.7	16.0	5.1	69.2	11.8	5.9	67.8	11.3	6.0
45	76.8	16.2	4.7	66.0	12.4	5.3	64.3	12.2	5.3
47	67.9	15.0	4.5	57.7	11.6	5.0	56.0	11.4	4.9
48	65.3	15.3	4.3	55.5	11.8	4.7			
50									
54									

Abbreviations:

HC: Total heating capacity (kW)

PI: Power input (kW)

LWT: Leaving water temperature (°C)

DB: Dry-bulb temperature for outdoor air temperature (°C)

Performance specifications measured with water pump operating at rated water flow rate.

MC-SU90M-RN8L-B

LWT	DB																	
	-20			-18			-15			-10			-7			4		
	HC	PI	COP	HC	PI	COP	HC	PI	COP	HC	PI	COP	HC	PI	COP	HC	PI	COP
25	44.7	22.6	2.0	49.6	23.3	2.1	56.8	24.3	2.3	67.4	24.7	2.7	73.7	25.0	2.9	79.1	25.8	3.1
30	43.9	23.2	1.9	48.7	23.9	2.0	55.8	24.9	2.2	66.2	25.4	2.6	72.4	25.7	2.8	77.7	26.5	2.9
35	42.7	26.3	1.6	47.0	26.8	1.8	53.6	27.4	2.0	63.9	27.6	2.3	70.2	27.7	2.5	75.5	27.8	2.7
40	39.7	28.1	1.4	44.2	28.5	1.6	51.0	29.1	1.8	61.6	29.7	2.1	68.0	30.1	2.3	73.7	30.2	2.4
42				42.4	28.2	1.5	48.9	28.8	1.7	59.9	30.1	2.0	66.5	30.9	2.2	72.2	31.0	2.3
45							45.8	28.4	1.6	57.2	30.7	1.9	64.1	32.1	2.0	69.9	32.3	2.2
47										50.6	28.6	1.8	56.6	29.9	1.9	63.6	30.8	2.1
48										48.6	29.2	1.7	54.5	30.5	1.8	61.2	31.4	1.9
50													48.0	29.5	1.6	55.3	30.8	1.8
54																47.5	31.1	1.5

LWT	DB																	
	2			7			15			20			25			30		
	HC	PI	COP	HC	PI	COP	HC	PI	COP	HC	PI	COP	HC	PI	COP	HC	PI	COP
25	89.9	27.4	3.3	102.0	25.3	4.0	104.8	24.6	4.3	104.9	23.2	4.5	102.8	21.5	4.8	100.0	19.1	5.2
30	88.3	28.1	3.1	101.4	26.0	3.9	103.9	25.2	4.1	104.0	23.8	4.4	101.9	22.0	4.6	99.2	19.6	5.1
35	86.3	27.9	3.1	100.2	27.9	3.6	102.4	26.4	3.9	102.3	25.0	4.1	100.2	22.2	4.5	96.0	19.8	4.8
40	84.9	30.3	2.8	95.7	28.5	3.4	99.1	27.3	3.6	99.6	26.0	3.8	99.3	23.0	4.3	94.6	20.2	4.7
42	83.5	31.3	2.7	92.8	29.0	3.2	98.5	28.3	3.5	98.9	26.5	3.7	98.3	23.3	4.2	90.7	20.3	4.5
45	81.5	32.8	2.5	90.4	30.3	3.0	97.7	29.7	3.3	98.2	27.0	3.6	96.8	23.8	4.1	84.9	20.3	4.2
47	77.6	32.6	2.4	86.5	32.7	2.6	93.5	28.6	3.3	90.1	24.3	3.7	83.7	20.9	4.0	74.6	18.9	3.9
48	74.6	33.3	2.2	83.2	33.4	2.5	89.9	29.1	3.1	86.6	24.8	3.5	80.5	21.3	3.8	71.8	19.3	3.7
50	70	33.6	2.1	78.3	33.7	2.3	84.7	28.7	3.0	79.1	23.7	3.3	75.6	20.7	3.7	63.0	18.6	3.4
54	59.9	34.8	1.7	67.0	35.5	1.9	73.9	28.5	2.6	70.2	22.7	3.1	58.9	17.2	3.4	47.0	15.9	3.0

LWT	DB								
	35			40			43		
	HC	PI	COP	HC	PI	COP	HC	PI	COP
25	93.6	16.5	5.7	89.6	15.1	5.9	88.8	15.0	5.9
30	92.8	16.9	5.5	88.9	15.5	5.7	88.0	15.3	5.8
35	89	18.2	4.9	80.0	14.8	5.4	78.6	13.9	5.7
40	85	17.5	4.9	71.4	12.9	5.5	70.1	12.2	5.7
42	81.7	17.5	4.7	69.2	13.3	5.2	67.8	12.8	5.3
45	76.8	17.7	4.3	66.0	13.9	4.7	64.3	13.7	4.7
47	67.9	16.5	4.1	57.7	13.1	4.4	56.0	12.9	4.3
48	65.3	16.8	3.9	55.5	13.3	4.2			
50									
54									

Abbreviations:

HC: Total heating capacity (kW)

PI: Power input (kW)

LWT: Leaving water temperature (°C)

DB: Dry-bulb temperature for outdoor air temperature (°C)

Performance specifications measured with water pump operating at rated water flow rate..

LWT	DB																	
	-20			-18			-15			-10			-5			0		
	HC	PI	COP	HC	PI	COP	HC	PI	COP	HC	PI	COP	HC	PI	COP	HC	PI	COP
25	60.4	27.2	2.2	78.8	31.9	2.5	81.7	32.4	2.5	97.1	35.9	2.7	82.7	30.0	2.8	91.4	31.3	2.9
30	61.9	28.9	2.1	78.5	32.8	2.4	80.0	33.8	2.4	95.2	37.4	2.5	82.6	31.7	2.6	91.8	33.6	2.7
35	57.2	29.3	1.9	74.4	34.0	2.2	80.4	36.6	2.2	95.6	40.5	2.4	83.5	34.8	2.4	92.2	36.3	2.5
40	38.1	23.1	1.7	67.4	34.9	1.9	81.4	39.5	2.1	96.7	43.8	2.2	85.2	37.4	2.3	90.8	38.7	2.3
45	13.0	12.1	1.1	54.9	33.4	1.6	79.5	42.5	1.9	94.5	47.0	2.0	86.9	42.2	2.1	89.4	41.4	2.2
48				50.9	33.0	1.5	75.4	41.7	1.8	89.7	46.1	1.9	84.1	42.5	2.0	87.3	42.6	2.0
50							69.8	40.9	1.7	83.0	45.3	1.8	75.4	39.6	1.9	80.3	41.4	1.9
54										57.7	35.4	1.6	55.6	32.9	1.7	56.4	32.7	1.7

LWT	DB																	
	5			7			10			15			20			25		
	HC	PI	COP	HC	PI	COP	HC	PI	COP	HC	PI	COP	HC	PI	COP	HC	PI	COP
25	120.1	35.5	3.4	158.9	42.4	3.7	169.7	43.1	3.9	180.1	45.1	4.0	196.8	48.1	4.1	213.6	51.5	4.2
30	116.2	36.9	3.2	150.6	43.3	3.5	166.2	44.3	3.8	178.3	47.2	3.8	188.4	48.9	3.9	198.5	50.9	3.9
35	112.8	37.5	3.0	138.5	42.1	3.3	161.7	45.0	3.6	172.0	47.1	3.6	180.7	48.3	3.7	186.2	48.4	3.9
40	110.5	40.0	2.8	138.8	44.7	3.1	158.9	46.5	3.4	166.0	47.8	3.5	169.2	47.7	3.5	173.0	47.4	3.6
45	107.6	42.4	2.5	138.0	44.5	3.1	156.9	50.1	3.1	148.6	46.5	3.2	155.8	44.8	3.5	158.1	43.9	3.6
48	107.5	45.1	2.4	130.6	46.3	2.8	153.8	51.1	3.0	140.0	44.6	3.1	148.2	43.8	3.4	151.1	42.9	3.5
50	106.5	46.6	2.3	123.7	47.0	2.6	147.8	51.9	2.8	130.1	42.5	3.1	133.5	39.8	3.4	136.1	39.4	3.5
54	66.2	33.0	2.0	71.4	31.2	2.3	80.2	31.0	2.6	86.5	30.4	2.8	85.6	27.5	3.1	89.0	27.6	3.2

LWT	DB											
	30			35			40			43		
	HC	PI	COP	HC	PI	COP	HC	PI	COP	HC	PI	COP
25	220.2	52.1	4.2	226.9	50.8	4.5	216.6	46.7	4.6	211.4	44.7	4.7
30	204.2	48.5	4.2	209.8	47.5	4.4	198.0	44.4	4.5	192.1	42.6	4.5
35	191.0	44.2	4.3	198.1	44.9	4.4	183.7	44.0	4.2	178.5	42.2	4.2
40	168.7	39.4	4.3	177.1	40.5	4.4	163.5	42.8	3.8	156.8	40.4	3.9
45	150.1	40.0	3.8	158.5	41.5	3.8	143.9	41.6	3.5	136.6	39.1	3.5
48	136.1	37.6	3.6	141.5	38.4	3.7	130.2	40.4	3.2	124.5	38.0	3.3
50	124.9	35.3	3.5	129.2	36.1	3.6	117.1	38.9	3.0	111.0	36.1	3.1
54	79.1	23.8	3.3	89.1	26.4	3.4	80.8	29.3	2.8			

Abbreviations:

HC: Total heating capacity (kW)

PI: Power input (kW)

LWT: Leaving water temperature (°C)

DB: Dry-bulb temperature for outdoor air temperature (°C)

Performance specifications measured with water pump operating at rated water flow rate.

MC-SU140M-RN8L-B

LWT	DB																	
	-20			-18			-15			-10			-5			0		
	HC	PI	COP	HC	PI	COP	HC	PI	COP	HC	PI	COP	HC	PI	COP	HC	PI	COP
25	60.4	29.4	2.1	78.8	34.1	2.3	81.7	34.6	2.4	97.1	38.1	2.5	82.7	32.2	2.6	91.4	33.5	2.7
30	61.9	31.1	2.0	78.5	35.0	2.2	80.0	36.0	2.2	95.2	39.6	2.4	82.6	33.9	2.4	91.8	35.8	2.6
35	57.2	31.5	1.8	74.4	36.2	2.1	80.4	38.8	2.1	95.6	42.7	2.2	83.5	37.0	2.3	92.2	38.5	2.4
40	38.1	25.3	1.5	67.4	37.1	1.8	81.4	41.7	2.0	96.7	46.0	2.1	85.2	39.6	2.2	90.8	40.9	2.2
45	13	14.3	0.9	54.9	35.6	1.5	79.5	44.7	1.8	94.5	49.2	1.9	86.9	44.4	2.0	89.4	43.6	2.1
48				50.9	35.2	1.4	75.4	43.9	1.7	89.7	48.3	1.9	84.1	44.7	1.9	87.3	44.8	1.9
50							69.8	43.1	1.6	83.0	47.5	1.7	75.4	41.8	1.8	80.3	43.6	1.8
54										57.7	37.6	1.5	55.6	35.1	1.6	56.4	34.9	1.6

LWT	DB																	
	5			7			10			15			20			25		
	HC	PI	COP	HC	PI	COP	HC	PI	COP	HC	PI	COP	HC	PI	COP	HC	PI	COP
25	120.1	37.7	3.2	158.9	44.6	3.6	169.7	45.3	3.7	180.1	47.3	3.8	196.8	50.3	3.9	213.6	53.7	4.0
30	116.2	39.1	3.0	150.6	45.5	3.3	166.2	46.5	3.6	178.3	49.4	3.6	188.4	51.1	3.7	198.5	53.1	3.7
35	112.8	39.7	2.8	138.5	44.3	3.1	161.7	47.2	3.4	172.0	49.3	3.5	180.7	50.5	3.6	186.2	50.6	3.7
40	110.5	42.2	2.6	138.8	46.9	3.0	158.9	48.7	3.3	166.0	50.0	3.3	169.2	49.9	3.4	173.0	49.6	3.5
45	107.6	44.6	2.4	138.0	46.7	3.0	156.9	52.3	3.0	148.6	48.7	3.1	155.8	47.0	3.3	158.1	46.1	3.4
48	107.5	47.3	2.3	130.6	48.5	2.7	153.8	53.3	2.9	140.0	46.8	3.0	148.2	46.0	3.2	151.1	45.1	3.4
50	106.5	48.8	2.2	123.7	49.2	2.5	147.8	54.1	2.7	130.1	44.7	2.9	133.5	42.0	3.2	136.1	41.6	3.3
54	66.2	35.2	1.9	71.4	33.4	2.1	80.2	33.2	2.4	86.5	32.6	2.7	85.6	29.7	2.9	89.0	29.8	3.0

LWT	DB											
	30			35			40			43		
	HC	PI	COP	HC	PI	COP	HC	PI	COP	HC	PI	COP
25	220.2	54.3	4.1	226.9	53.0	4.3	216.6	48.9	4.4	211.4	46.9	4.5
30	204.2	50.7	4.0	209.8	49.7	4.2	198.0	46.6	4.2	192.1	44.8	4.3
35	191	46.4	4.1	198.1	47.1	4.2	183.7	46.2	4.0	178.5	44.4	4.0
40	168.7	41.6	4.1	177.1	42.7	4.1	163.5	45.0	3.6	156.8	42.6	3.7
45	150.1	42.2	3.6	158.5	43.7	3.6	143.9	43.8	3.3	136.6	41.3	3.3
48	136.1	39.8	3.4	141.5	40.6	3.5	130.2	42.6	3.1	124.5	40.2	3.1
50	124.9	37.5	3.3	129.2	38.3	3.4	117.1	41.1	2.8	111.0	38.3	2.9
54	79.1	26	3.0	89.1	28.6	3.1	80.8	31.5	2.6			

Abbreviations:

HC: Total heating capacity (kW)

PI: Power input (kW)

LWT: Leaving water temperature (°C)

DB: Dry-bulb temperature for outdoor air temperature (°C)

Performance specifications measured with water pump operating at rated water flow rate.

LWT	DB																	
	-20			-18			-15			-10			-7			-4		
	HC	PI	COP	HC	PI	COP	HC	PI	COP	HC	PI	COP	HC	PI	COP	HC	PI	COP
25	89.5	42.5	43.9	99.1	43.9	2.3	111.8	45.7	2.4	134.8	46.8	2.9	148.1	48.1	3.1	158.2	48.9	3.2
30	87.9	43.7	45.1	97.4	45.1	2.2	109.8	47.0	2.3	132.4	48.1	2.8	145.5	49.4	2.9	155.4	50.3	3.1
35	85.3	50.0	50.8	94.1	50.8	1.9	106.0	51.9	2.0	127.9	52.5	2.4	141.0	52.7	2.7	151.1	52.9	2.9
40	79.4	53.6	54.4	88.4	54.4	1.6	100.8	55.9	1.8	123.3	56.9	2.2	136.9	57.4	2.4	147.3	57.7	2.6
42				84.8	56.9	1.5	97.3	57.3	1.7	120.3	57.6	2.1	134.2	58.7	2.3	144.8	59.3	2.4
45							92.7	59.8	1.5	114.5	58.8	1.9	128.8	60.7	2.1	139.8	62.0	2.3
47										103.8	57.3	1.8	118.1	59.7	2.0	129.0	61.2	2.1
48										97.2	55.8	1.7	111.4	58.5	1.9	122.3	60.3	2.0
50													101.0	57.4	1.8	110.7	59.1	1.9
54																95.0	59.5	1.6

LWT	DB																	
	0			5			7			10			15			20		
	HC	PI	COP	HC	PI	COP	HC	PI	COP	HC	PI	COP	HC	PI	COP	HC	PI	COP
25	174.3	51.2	3.4	190.3	47.0	4.1	198.2	46.5	4.3	206.0	45.4	4.5	207.5	44.8	4.6	207.8	43.6	4.8
30	171.2	52.6	3.3	188.0	48.6	3.9	196.5	47.0	4.2	204.2	46.8	4.4	205.7	46.1	4.5	206.0	44.9	4.6
35	167.1	53.1	3.1	183.0	49.9	3.7	190.8	49.6	3.9	199.2	49.8	4.0	200.9	49.2	4.1	200.5	47.4	4.2
40	164.0	57.9	2.8	178.6	56.2	3.2	185.4	54.2	3.4	196.1	51.8	3.8	198.2	51.1	3.9	199.2	49.4	4.0
42	161.7	59.8	2.7	176.8	57.0	3.1	183.9	55.4	3.3	195.0	53.6	3.6	197.3	52.9	3.7	198.1	49.8	4.0
45	157.0	62.7	2.5	173.3	58.3	3.0	180.0	57.0	3.2	193.0	56.5	3.4	195.4	55.7	3.5	196.0	50.3	3.9
47	147.3	63.0	2.3	166.7	63.3	2.6	175.3	61.6	2.8	184.1	56.2	3.3	185.7	55.1	3.4	181.9	48.4	3.8
48	142.1	63.0	2.3	162.6	66.1	2.5	172.3	64.2	2.7	178.6	55.7	3.2	179.8	54.5	3.3	173.3	46.9	3.7
50	132.2	63.2	2.1	155.5	67.3	2.3	166.6	69.2	2.4	168.9	53.6	3.2	169.4	52.1	3.3	158.2	44.7	3.5
54	113.2	65.1	1.7	132.8	67.4	2.0	142.1	68.4	2.1	146.8	52.3	2.8	147.8	50.9	2.9	140.5	42.7	3.3

LWT	DB														
	25			30			35			40			43		
	HC	PI	COP	HC	PI	COP	HC	PI	COP	HC	PI	COP	HC	PI	COP
25	205.7	40.2	5.1	200.1	35.5	5.6	187.3	30.1	6.2	179.2	28.5	6.3	177.6	27.7	6.4
30	203.9	41.3	4.9	198.4	36.5	5.4	185.7	31.0	6.0	177.7	29.3	6.1	176.1	28.5	6.2
35	200.5	41.4	4.8	192.0	36.8	5.2	178.0	32.0	5.6	160.0	27.9	5.7	157.2	26.8	5.9
40	198.6	42.7	4.7	189.2	37.6	5.0	170.0	32.9	5.2	142.8	26.0	5.5	140.1	25.0	5.6
42	196.9	43.8	4.5	182.7	37.7	4.8	164.5	32.7	5.0	139.1	26.0	5.3	136.3	24.9	5.5
45	193.6	45.6	4.3	169.8	37.9	4.5	153.6	32.5	4.7	132.0	25.9	5.1	128.6	24.7	5.2
47	173.4	42.7	4.1	155.6	36.4	4.3	141.7	31.6	4.5	124.1	25.4	4.9	120.2	23.9	5.0
48	161.0	40.6	4.0	143.5	34.5	4.2	130.6	29.8	4.4	114.4	24.0	4.8			
50	139.2	37.3	3.7	126.0	32.4	3.9									
54	117.9	33.3	3.5	94.0	25.3	3.7									

Abbreviations:

HC: Total heating capacity (kW)

PI: Power input (kW)

LWT: Leaving water temperature (°C)

DB: Dry-bulb temperature for outdoor air temperature (°C)

Performance specifications measured with water pump operating at rated water flow rate..

MC-SU180M-RN8L-B

LWT	DB																	
	-20			-18			-15			-10			-7			-4		
	HC	PI	COP	HC	PI	COP	HC	PI	COP	HC	PI	COP	HC	PI	COP	HC	PI	COP
25	89.5	44.0	2.0	99.1	45.4	2.2	111.8	47.2	2.4	134.8	48.3	2.8	148.1	49.6	3.0	158.2	50.4	3.1
30	87.9	45.2	1.9	97.4	46.6	2.1	109.8	48.5	2.3	132.4	49.6	2.7	145.5	50.9	2.9	155.4	51.8	3.0
35	85.3	51.5	1.7	94.1	52.3	1.8	106.0	53.4	2.0	127.9	54.0	2.4	141.0	54.2	2.6	151.1	54.4	2.8
40	79.4	55.1	1.4	88.4	55.9	1.6	100.8	57.4	1.8	123.3	58.4	2.1	136.9	58.9	2.3	147.3	59.2	2.5
42				84.8	58.4	1.5	97.3	58.8	1.7	120.3	59.1	2.0	134.2	60.2	2.2	144.8	60.8	2.4
45							92.7	61.3	1.5	114.5	60.3	1.9	128.8	62.2	2.1	139.8	63.5	2.2
47										103.8	58.8	1.8	118.1	61.2	1.9	129.0	62.7	2.1
48										97.2	57.3	1.7	111.4	60.0	1.9	122.3	61.8	2.0
50													101.0	58.9	1.7	110.7	60.6	1.8
54																95.0	61.0	1.6

LWT	DB																	
	0			5			7			10			15			20		
	HC	PI	COP	HC	PI	COP	HC	PI	COP	HC	PI	COP	HC	PI	COP	HC	PI	COP
25	174.3	52.7	3.3	190.3	48.5	3.9	198.2	48.0	4.1	206.0	46.9	4.4	207.5	46.3	4.5	207.8	45.1	4.6
30	171.2	54.1	3.2	188.0	50.1	3.8	196.5	48.5	4.1	204.2	48.3	4.2	205.7	47.6	4.3	206.0	46.4	4.4
35	167.1	54.6	3.1	183.0	51.4	3.6	190.8	51.1	3.7	199.2	51.3	3.9	200.9	50.7	4.0	200.5	48.9	4.1
40	164.0	59.4	2.8	178.6	57.7	3.1	185.4	55.7	3.3	196.1	53.3	3.7	198.2	52.6	3.8	199.2	50.9	3.9
42	161.7	61.3	2.6	176.8	58.5	3.0	183.9	56.9	3.2	195.0	55.1	3.5	197.3	54.4	3.6	198.1	51.3	3.9
45	157.0	64.2	2.4	173.3	59.8	2.9	180.0	58.5	3.1	193.0	58.0	3.3	195.4	57.2	3.4	196.0	51.8	3.8
47	147.3	64.5	2.3	166.7	64.8	2.6	175.3	63.1	2.8	184.1	57.7	3.2	185.7	56.6	3.3	181.9	49.9	3.6
48	142.1	64.5	2.2	162.6	67.6	2.4	172.3	65.7	2.6	178.6	57.2	3.1	179.8	56.0	3.2	173.3	48.4	3.6
50	132.2	64.7	2.0	155.5	68.8	2.3	166.6	70.7	2.4	168.9	55.1	3.1	169.4	53.6	3.2	158.2	46.2	3.4
54	113.2	66.6	1.7	132.8	68.9	1.9	142.1	69.9	2.0	146.8	53.8	2.7	147.8	52.4	2.8	140.5	44.2	3.2

LWT	DB														
	25			30			35			40			43		
	HC	PI	COP	HC	PI	COP	HC	PI	COP	HC	PI	COP	HC	PI	COP
25	205.7	41.7	4.9	200.1	37.0	5.4	187.3	31.6	5.9	179.2	30.0	6.0	177.6	29.2	6.1
30	203.9	42.8	4.8	198.4	38.0	5.2	185.7	32.5	5.7	177.7	30.8	5.8	176.1	30.0	5.9
35	200.5	42.9	4.7	192.0	38.3	5.0	178.0	33.5	5.3	160.0	29.4	5.4	157.2	28.3	5.6
40	198.6	44.2	4.5	189.2	39.1	4.8	170.0	34.4	4.9	142.8	27.5	5.2	140.1	26.5	5.3
42	196.9	45.3	4.3	182.7	39.2	4.7	164.5	34.2	4.8	139.1	27.5	5.1	136.3	26.4	5.2
45	193.6	47.1	4.1	169.8	39.4	4.3	153.6	34.0	4.5	132.0	27.4	4.8	128.6	26.2	4.9
47	173.4	44.2	3.9	155.6	37.9	4.1	141.7	33.1	4.3	124.1	26.9	4.6	120.2	25.4	4.7
48	161.0	42.1	3.8	143.5	36.0	4.0	130.6	31.3	4.2	114.4	25.5	4.5			
50	139.2	38.8	3.6	126.0	33.9	3.7									
54	117.9	34.8	3.4	94.0	26.8	3.5									

Abbreviations:

HC: Total heating capacity (kW)

PI: Power input (kW)

LWT: Leaving water temperature (°C)

DB: Dry-bulb temperature for outdoor air temperature (°C)

Performance specifications measured with water pump operating at rated water flow rate.

5.2 Cooling Capacity Tables

MC-SU75-RN8L-B

LWT	DB																	
	-10			-5			0			5			10			15		
	CC	PI	EER	CC	PI	EER	CC	PI	EER	CC	PI	EER	CC	PI	EER	CC	PI	EER
0													52.0	17.7	2.9	61.1	17.7	3.5
5													60.5	18.6	3.3	69.0	18.9	3.7
7													66.7	19.8	3.4	75.5	20.2	3.7
10	61.9	10.3	6.0	61.0	11.0	5.6	58.9	11.7	5.0	57.2	12.5	4.6	68.2	19.8	3.4	82.3	20.8	4.0
15	70.8	10.4	6.8	69.6	11.6	6.0	66.5	11.4	5.8	65.4	11.6	5.7	66.9	17.4	3.8	90.8	18.4	4.9
20	78.4	11.3	6.9	77.5	12.0	6.5	76.5	12.3	6.2	74.4	12.1	6.2	68.3	16.7	4.1	95.9	18.6	5.2

LWT	DB																	
	20			25			30			35			40			43		
	CC	PI	EER	CC	PI	EER	CC	PI	EER	CC	PI	EER	CC	PI	EER	CC	PI	EER
0	60.5	18.0	3.4	59.9	18.7	3.2	59.4	22.3	2.7	56.9	24.3	2.3	36.5	16.5	2.2	23.2	11.4	2.0
5	68.2	19.3	3.5	67.6	20.0	3.4	67.0	23.8	2.8	64.2	26.0	2.5	41.2	17.6	2.3	26.2	12.1	2.2
7	75.1	20.4	3.7	74.2	21.4	3.5	70.8	24.2	2.9	70.0	26.8	2.6	47.3	18.8	2.5	31.8	13.5	2.4
10	81.2	21.1	3.8	79.3	21.4	3.7	77.4	24.9	3.1	74.8	27.1	2.8	51.6	19.1	2.7	35.5	13.7	2.6
15	88.0	19.5	4.5	86.8	20.9	4.2	82.4	23.0	3.6	78.7	24.5	3.2	53.2	16.8	3.2	37.1	12.5	3.0
20	94.5	19.6	4.8	93.5	21.3	4.4	91.6	23.0	4.0	87.4	23.2	3.8	58.0	15.8	3.7	43.3	12.7	3.4

LWT	DB					
	45			48		
	CC	PI	EER	CC	PI	EER
0	21.3	11.2	1.9	11.3	8.3	1.4
5	24.1	11.9	2.0	12.7	8.9	1.4
7	27.4	12.6	2.2	14.5	8.9	1.6
10	31.2	12.9	2.4	17.1	9.0	1.9
15	33.9	12.1	2.8	21.3	9.0	2.4
20	39.0	12.3	3.2	25.1	9.0	2.8

Abbreviations:

CC: Total cooling capacity (kW)

PI: Power input (kW)

LWT: Leaving water temperature (°C)

DB: Dry-bulb temperature for outdoor air temperature (°C)

Notes: Performance specifications measured with water pump operating at rated water flow rate.

MC-SU75M-RN8L-B

LWT	DB																	
	-10			-5			0			5			10			15		
	CC	PI	EER	CC	PI	EER	CC	PI	EER	CC	PI	EER	CC	PI	EER	CC	PI	EER
0													52.0	19.2	2.7	61.1	19.2	3.2
5													60.5	20.1	3.0	69.0	20.4	3.4
7													66.7	21.3	3.1	75.5	21.7	3.5
10	61.9	11.8	5.2	61.0	12.5	4.9	58.9	13.2	4.5	57.2	14.0	4.1	68.2	21.3	3.2	82.3	22.3	3.7
15	70.8	11.9	5.9	69.6	13.1	5.3	66.5	12.9	5.2	65.4	13.1	5.0	66.9	18.9	3.5	90.8	19.9	4.6
20	78.4	12.8	6.1	77.5	13.5	5.7	76.5	13.8	5.5	74.4	13.6	5.5	68.3	18.2	3.8	95.9	20.1	4.8

LWT	DB																	
	20			25			30			35			40			43		
	CC	PI	EER	CC	PI	EER	CC	PI	EER	CC	PI	EER	CC	PI	EER	CC	PI	EER
0	60.5	19.5	3.1	59.9	20.2	3.0	59.4	23.8	2.5	56.9	25.8	2.2	36.5	18.0	2.0	23.2	12.9	1.8
5	68.2	20.8	3.3	67.6	21.5	3.1	67.0	25.3	2.6	64.2	27.5	2.3	41.2	19.1	2.2	26.2	13.6	1.9
7	75.1	21.9	3.4	74.2	22.9	3.2	70.8	25.7	2.8	70.0	28.3	2.5	47.3	20.3	2.3	31.8	15.0	2.1
10	81.2	22.6	3.6	79.3	22.9	3.5	77.4	26.4	2.9	74.8	28.6	2.6	51.6	20.6	2.5	35.5	15.2	2.3
15	88	21	4.2	86.8	22.4	3.9	82.4	24.5	3.4	78.7	26.0	3.0	53.2	18.3	2.9	37.1	14.0	2.7
20	94.5	21.1	4.5	93.5	22.8	4.1	91.6	24.5	3.7	87.4	24.7	3.5	58.0	17.3	3.4	43.3	14.2	3.0

LWT	DB					
	45			48		
	CC	PI	EER	CC	PI	EER
0	21.3	12.7	1.7	11.3	9.8	1.2
5	24.1	13.4	1.8	12.7	10.4	1.2
7	27.4	14.1	1.9	14.5	10.4	1.4
10	31.2	14.4	2.2	17.1	10.5	1.6
15	33.9	13.6	2.5	21.3	10.5	2.0
20	39.0	13.8	2.8	25.1	10.5	2.4

Abbreviations:

CC: Total cooling capacity (kW)

PI: Power input (kW)

LWT: Leaving water temperature (°C)

DB: Dry-bulb temperature for outdoor air temperature (°C)

Notes: Performance specifications measured with water pump operating at rated water flow rate.

Aqua thermal



MC-SU90-RN8L-B

LWT	DB																	
	-10			-5			0			5			10			15		
	CC	PI	EER	CC	PI	EER	CC	PI	EER	CC	PI	EER	CC	PI	EER	CC	PI	EER
0													81.9	18.8	4.4	81.5	25.5	3.2
5													94.1	26.8	3.5	93.1	27.3	3.4
7													96.3	29.6	3.3	95.6	26.4	3.6
10	75.8	18.6	4.1	75.9	16.0	4.8	76.6	15.2	5.0	75.8	17.4	4.4	106.0	27.4	3.9	111.7	29.5	3.8
15	84.0	16.4	5.1	84.1	16.2	5.2	84.0	16.9	5.0	84.1	14.8	5.7	123.7	25.6	4.8	127.2	28.1	4.5
20	92.3	14.2	6.5	92.3	16.4	5.6	91.3	18.6	4.9	91.1	14.6	6.2	129.2	26.3	4.9	133.9	28.7	4.7

LWT	DB																	
	20			25			30			35			40			43		
	CC	PI	EER	CC	PI	EER	CC	PI	EER	CC	PI	EER	CC	PI	EER	CC	PI	EER
0	78.2	26.5	3.0	76.1	20.9	3.6	74.1	24.3	3.1	68.3	29.6	2.3	57.3	27.5	2.1	46.9	24.9	1.9
5	91.8	28.7	3.2	90.3	27.8	3.2	87.4	29.5	3.0	80.9	32.2	2.5	69.9	30.2	2.3	60.9	28.2	2.2
7	94.7	30.0	3.2	93.1	21.6	4.3	89.1	28.9	3.1	82.1	27.3	3.0	71.5	25.9	2.8	63.7	24.2	2.6
10	107.6	31.5	3.4	102.9	27.5	3.7	99.9	30.3	3.3	93.7	33.0	2.8	81.6	27.7	3.0	72.2	24.2	3.0
15	117.3	29.3	4.0	111.7	25.6	4.4	108.3	25.2	4.3	104.2	28.4	3.7	92.6	28.0	3.3	81.8	24.0	3.4
20	127.1	29.4	4.3	121.3	23.5	5.2	117.3	24.7	4.7	112.4	27.5	4.1	102.3	27.9	3.7	92.1	25.3	3.6

LWT	DB					
	45			48		
	CC	PI	EER	CC	PI	EER
0	32.8	20.1	1.6	18.0	12.1	1.5
5	48.5	24.2	2.0	29.3	16.5	1.8
7	56.0	21.8	2.6	38.1	18.0	2.1
10	62.9	22.4	2.8	45.1	19.2	2.4
15	72.8	23.4	3.1	55.0	17.8	3.1
20	80.7	22.2	3.6	60.9	19.3	3.1

Abbreviations:

CC: Total cooling capacity (kW)

PI: Power input (kW)

LWT: Leaving water temperature (°C)

DB: Dry-bulb temperature for outdoor air temperature (°C)

Notes: Performance specifications measured with water pump operating at rated water flow rate.

MC-SU90M-RN8L-B

LWT	DB																	
	-10			-5			0			5			10			15		
	CC	PI	EER	CC	PI	EER	CC	PI	EER	CC	PI	EER	CC	PI	EER	CC	PI	EER
0													81.9	20.3	4.0	81.5	27.0	3.0
5													94.1	28.3	3.3	93.1	28.8	3.2
7													96.3	31.1	3.1	95.6	27.9	3.4
10	75.8	20.1	3.8	75.9	17.5	4.3	76.6	16.7	4.6	75.8	18.9	4.0	106.0	28.9	3.7	111.7	31.0	3.6
15	84.0	17.9	4.7	84.1	17.7	4.8	84.0	18.4	4.6	84.1	16.3	5.2	123.7	27.1	4.6	127.2	29.6	4.3
20	92.3	15.7	5.9	92.3	17.9	5.2	91.3	20.1	4.5	91.1	16.1	5.7	129.2	27.8	4.6	133.9	30.2	4.4

LWT	DB																	
	20			25			30			35			40			43		
	CC	PI	EER	CC	PI	EER	CC	PI	EER	CC	PI	EER	CC	PI	EER	CC	PI	EER
0	78.2	28.0	2.8	76.1	22.4	3.4	74.1	25.8	2.9	68.3	31.1	2.2	57.3	29.0	2.0	46.9	26.4	1.8
5	91.8	30.2	3.0	90.3	29.3	3.1	87.4	31.0	2.8	80.9	33.7	2.4	69.9	31.7	2.2	60.9	29.7	2.1
7	94.7	31.5	3.0	93.1	23.1	4.0	89.1	30.4	2.9	82.1	28.8	2.9	71.5	27.4	2.6	63.7	25.7	2.5
10	107.6	33.0	3.3	102.9	29.0	3.5	99.9	31.8	3.1	93.7	34.5	2.7	81.6	29.2	2.8	72.2	25.7	2.8
15	117.3	30.8	3.8	111.7	27.1	4.1	108.3	26.7	4.1	104.2	29.9	3.5	92.6	29.5	3.1	81.8	25.5	3.2
20	127.1	30.9	4.1	121.3	25.0	4.9	117.3	26.2	4.5	112.4	29.0	3.9	102.3	29.4	3.5	92.1	26.8	3.4

LWT	DB					
	45			48		
	CC	PI	EER	CC	PI	EER
0	32.8	21.6	1.5	18.0	13.6	1.3
5	48.5	25.7	1.9	29.3	18.0	1.6
7	56.0	23.3	2.4	38.1	19.5	2.0
10	62.9	23.9	2.6	45.1	20.7	2.2
15	72.8	24.9	2.9	55.0	19.3	2.8
20	80.7	23.7	3.4	60.9	20.8	2.9

Abbreviations:

CC: Total cooling capacity (kW)

PI: Power input (kW)

LWT: Leaving water temperature (°C)

DB: Dry-bulb temperature for outdoor air temperature (°C)

Notes: Performance specifications measured with water pump operating at rated water flow rate.

Aqua thermal



MC-SU140-RN8L-B

LWT	DB																	
	-10			-5			0			5			10			15		
	CC	PI	EER	CC	PI	EER	CC	PI	EER	CC	PI	EER	CC	PI	EER	CC	PI	EER
0													105.2	38.4	2.7	117.4	38.0	3.1
5													120.0	40.8	2.9	135.2	40.4	3.3
7													128.2	42.7	3.0	142.2	41.2	3.5
10	114.4	25.6	4.5	112.8	25.7	4.4	111.3	26.1	4.3	109.7	26.4	4.2	133.3	42.8	3.1	146.5	41.6	3.5
15	133.7	26.3	5.1	131.8	26.2	5.0	130.5	26.4	4.9	129.2	26.6	4.9	138.2	40.7	3.4	155.0	38.5	4.0
20	144.7	25.0	5.8	143.1	25.4	5.6	141.6	25.7	5.5	140.1	25.9	5.4	146.6	40.7	3.6	156.3	37.1	4.2

LWT	DB																	
	20			25			30			35			40			43		
	CC	PI	EER	CC	PI	EER	CC	PI	EER	CC	PI	EER	CC	PI	EER	CC	PI	EER
0	111.5	38.8	2.9	110.1	40.5	2.7	108.4	44.5	2.4	106.5	49.8	2.1	86.5	41.8	2.1	74.1	38.0	1.9
5	128.4	41.1	3.1	125.6	43.3	2.9	124.5	46.8	2.7	121.7	52.9	2.3	98.3	44.5	2.2	85.1	40.6	2.1
7	136.9	41.6	3.3	133.5	45.3	3.0	132.1	47.9	2.8	130.0	50.5	2.6	104.8	43.0	2.4	91.2	41.3	2.2
10	142.8	42.4	3.4	142.1	46.1	3.1	141.1	49.0	2.9	139.1	52.5	2.7	107.7	41.3	2.6	100.9	40.9	2.5
15	151.0	39.9	3.8	148.3	44.3	3.3	147.4	46.7	3.2	146.2	49.3	3.0	115.5	40.3	2.9	110.3	39.9	2.8
20	152.9	38.1	4.0	150.2	42.4	3.5	149.8	44.7	3.4	148.4	46.9	3.2	119.9	38.7	3.1	114.9	37.7	3.0

LWT	DB					
	45			48		
	CC	PI	EER	CC	PI	EER
0	71.4	39.7	1.8	41.0	28.2	1.5
5	81.1	42.0	1.9	46.8	29.8	1.6
7	86.4	41.9	2.1	57.7	31.7	1.8
10	92.6	39.0	2.4	63.5	32.3	2.0
15	95.0	35.4	2.7	65.3	29.1	2.2
20	97.3	32.6	3.0	70.3	26.3	2.7

Abbreviations:

CC: Total cooling capacity (kW)

PI: Power input (kW)

LWT: Leaving water temperature (°C)

DB: Dry-bulb temperature for outdoor air temperature (°C)

Notes: Performance specifications measured with water pump operating at rated water flow rate.

MC-SU140M-RN8L-B

LWT	DB																	
	-10			-5			0			5			10			15		
	CC	PI	EER	CC	PI	EER	CC	PI	EER	CC	PI	EER	CC	PI	EER	CC	PI	EER
0													105.2	40.6	2.6	117.4	40.2	2.9
5													120.0	43.0	2.8	135.2	42.6	3.2
7													128.2	44.9	2.9	142.2	43.4	3.3
10	114.4	27.8	4.1	112.8	27.9	4.0	111.3	28.3	3.9	109.7	28.6	3.8	133.3	45.0	3.0	146.5	43.8	3.3
15	133.7	28.5	4.7	131.8	28.4	4.6	130.5	28.6	4.6	129.2	28.8	4.5	138.2	42.9	3.2	155.0	40.7	3.8
20	144.7	27.2	5.3	143.1	27.6	5.2	141.6	27.9	5.1	140.1	28.1	5.0	146.6	42.9	3.4	156.3	39.3	4.0

LWT	DB																	
	20			25			30			35			40			43		
	CC	PI	EER	CC	PI	EER	CC	PI	EER	CC	PI	EER	CC	PI	EER	CC	PI	EER
0	111.5	41	2.7	110.1	42.7	2.6	108.4	46.7	2.3	106.5	52.0	2.0	86.5	44.0	2.0	74.1	40.2	1.8
5	128.4	43.3	3.0	125.6	45.5	2.8	124.5	49.0	2.5	121.7	55.1	2.2	98.3	46.7	2.1	85.1	42.8	2.0
7	136.9	43.8	3.1	133.5	47.5	2.8	132.1	50.1	2.6	130.0	52.7	2.5	104.8	45.2	2.3	91.2	43.5	2.1
10	142.8	44.6	3.2	142.1	48.3	2.9	141.1	51.2	2.8	139.1	54.7	2.5	107.7	43.5	2.5	100.9	43.1	2.3
15	151	42.1	3.6	148.3	46.5	3.2	147.4	48.9	3.0	146.2	51.5	2.8	115.5	42.5	2.7	110.3	42.1	2.6
20	152.9	40.3	3.8	150.2	44.6	3.4	149.8	46.9	3.2	148.4	49.1	3.0	119.9	40.9	2.9	114.9	39.9	2.9

LWT	DB					
	45			48		
	CC	PI	EER	CC	PI	EER
0	71.4	41.9	1.7	41.0	30.4	1.3
5	81.1	44.2	1.8	46.8	32.0	1.5
7	86.4	44.1	2.0	57.7	33.9	1.7
10	92.6	41.2	2.2	63.5	34.5	1.8
15	95	37.6	2.5	65.3	31.3	2.1
20	97.3	34.8	2.8	70.3	28.5	2.5

Abbreviations:

CC: Total cooling capacity (kW)

PI: Power input (kW)

LWT: Leaving water temperature (°C)

DB: Dry-bulb temperature for outdoor air temperature (°C)

Notes: Performance specifications measured with water pump operating at rated water flow rate.

Aqua thermal



MC-SU180-RN8L-B

LWT	DB																	
	-10			-5			0			5			10			15		
	CC	PI	EER	CC	PI	EER	CC	PI	EER	CC	PI	EER	CC	PI	EER	CC	PI	EER
0													163.8	48.5	3.4	163.1	51.1	3.2
5													188.2	52.0	3.6	186.3	54.7	3.4
7													199.1	52.2	3.8	197.6	55.0	3.6
10	151.7	37.3	4.1	151.8	32.0	4.7	153.3	30.5	5.0	151.6	34.9	4.3	212.0	52.7	4.0	223.5	59.2	3.8
15	168.1	32.8	5.1	168.2	32.5	5.2	168.0	31.6	5.3	168.2	29.7	5.7	247.4	51.4	4.8	254.4	56.4	4.5
20	184.5	28.4	6.5	184.5	32.9	5.6	182.6	30.6	6.0	182.3	29.3	6.2	258.5	48.6	5.3	267.8	56.3	4.8

LWT	DB																	
	20			25			30			35			40			43		
	CC	PI	EER	CC	PI	EER	CC	PI	EER	CC	PI	EER	CC	PI	EER	CC	PI	EER
0	156.5	50.5	3.1	152.1	50.4	3.0	148.2	48.8	3.0	136.7	59.3	2.3	114.7	55.3	2.1	93.8	50.0	1.9
5	183.5	56.3	3.3	180.6	57.7	3.1	174.9	59.1	3.0	161.7	64.7	2.5	139.8	60.7	2.3	121.9	56.7	2.2
7	195.6	57.2	3.4	192.4	59.6	3.2	184.2	60.2	3.1	164.0	56.0	2.9	147.7	54.0	2.7	131.7	50.3	2.6
10	215.1	59.4	3.6	205.8	60.0	3.4	199.7	60.7	3.3	187.5	59.5	3.1	163.3	54.8	3.0	144.4	50.0	2.9
15	234.6	58.8	4.0	223.4	51.4	4.3	216.5	50.5	4.3	208.4	56.9	3.7	185.1	56.3	3.3	163.7	50.7	3.2
20	254.3	59.0	4.3	242.7	47.1	5.2	234.6	49.7	4.7	224.7	55.2	4.1	204.7	55.9	3.7	184.2	52.5	3.5

LWT	DB					
	45			48		
	CC	PI	EER	CC	PI	EER
0	65.6	40.3	1.6	36.0	24.4	1.5
5	96.9	48.6	2.0	58.6	33.2	1.8
7	115.7	45.5	2.5	78.6	37.6	2.1
10	125.8	45.0	2.8	90.2	38.5	2.3
15	145.6	46.9	3.1	110.0	38.6	2.9
20	161.3	48.0	3.4	121.7	38.8	3.1

Abbreviations:

CC: Total cooling capacity (kW)

PI: Power input (kW)

LWT: Leaving water temperature (°C)

DB: Dry-bulb temperature for outdoor air temperature (°C)

Notes: Performance specifications measured with water pump operating at rated water flow rate.

MC-SU180M-RN8L-B

LWT	DB																	
	-10			-5			0			5			10			15		
	CC	PI	EER	CC	PI	EER	CC	PI	EER	CC	PI	EER	CC	PI	EER	CC	PI	EER
0													163.8	50.0	3.3	163.1	52.6	3.1
5													188.2	53.5	3.5	186.3	56.2	3.3
7													199.1	53.7	3.7	197.6	56.5	3.5
10	151.7	38.8	3.9	151.8	33.5	4.5	153.3	32.0	4.8	151.6	36.4	4.2	212.0	54.2	3.9	223.5	60.7	3.7
15	168.1	34.3	4.9	168.2	34.0	4.9	168.0	33.1	5.1	168.2	31.2	5.4	247.4	52.9	4.7	254.4	57.9	4.4
20	184.5	29.9	6.2	184.5	34.4	5.4	182.6	32.1	5.7	182.3	30.8	5.9	258.5	50.1	5.2	267.8	57.8	4.6

LWT	DB																	
	20			25			30			35			40			43		
	CC	PI	EER	CC	PI	EER	CC	PI	EER	CC	PI	EER	CC	PI	EER	CC	PI	EER
0	156.5	52	3.0	152.1	51.9	2.9	148.2	50.3	2.9	136.7	60.8	2.2	114.7	56.8	2.0	93.8	51.5	1.8
5	183.5	57.8	3.2	180.6	59.2	3.1	174.9	60.6	2.9	161.7	66.2	2.4	139.8	62.2	2.2	121.9	58.2	2.1
7	195.6	58.7	3.3	192.4	61.1	3.1	184.2	61.7	3.0	164.0	57.5	2.9	147.7	55.5	2.7	131.7	51.8	2.5
10	215.1	60.9	3.5	205.8	61.5	3.3	199.7	62.2	3.2	187.5	61.0	3.1	163.3	56.3	2.9	144.4	51.5	2.8
15	234.6	60.3	3.9	223.4	52.9	4.2	216.5	52.0	4.2	208.4	58.4	3.6	185.1	57.8	3.2	163.7	52.2	3.1
20	254.3	60.5	4.2	242.7	48.6	5.0	234.6	51.2	4.6	224.7	56.7	4.0	204.7	57.4	3.6	184.2	54.0	3.4

LWT	DB					
	45			48		
	CC	PI	EER	CC	PI	EER
0	65.6	41.8	1.6	36.0	25.9	1.4
5	96.9	50.1	1.9	58.6	34.7	1.7
7	115.7	47.0	2.5	78.6	39.1	2.0
10	125.8	46.5	2.7	90.2	40.0	2.3
15	145.6	48.4	3.0	110.0	40.1	2.7
20	161.3	49.5	3.3	121.7	40.3	3.0

Abbreviations:

CC: Total cooling capacity (kW)

PI: Power input (kW)

LWT: Leaving water temperature (°C)

DB: Dry-bulb temperature for outdoor air temperature (°C)

Notes: Performance specifications measured with water pump operating at rated water flow rate.

6 Performance Adjustment Factors

6.1 Ethylene and Propylene Glycol factors

The antifreeze must be required according to anyone condition as following:

- The ambient temperature is below 0 °C;
- Don't start up the unit for a long time.
- The power supply was cut off and needn't change the water in system.

A glycol solution is required when the unit with condition as mentioned. The use of glycol will reduce the performance of the unit depending on concentration.

Concentration of ethylene glycol (%)	Modification coefficient				Freezing point (°C)
	Cooling capacity	Power input	Water resistance	Water flow	
0	1.000	1.000	1.000	1.000	0
10	0.984	0.998	1.118	1.019	-4
20	0.973	0.995	1.268	1.051	-9
30	0.965	0.992	1.482	1.092	-16
40	0.960	0.989	1.791	1.145	-23
50	0.950	0.983	2.100	1.200	-37

Concentration of propylene glycol (%)	Modification coefficient				Freezing point (°C)
	Cooling capacity	Power input	Water resistance	Water flow	
0	1.000	1.000	1.000	1.000	0
10	0.976	0.996	1.071	1.00	-3
20	0.961	0.992	1.189	1.016	-7
30	0.948	0.988	1.380	1.034	-13
40	0.938	0.984	1.728	1.078	-22
50	0.925	0.975	2.150	1.125	-35

6.2 Evaporator temperature drop factors

Performance tables are based on a 5°C temperature drop through the evaporator. Temperature drops outside this range can affect the control system's capability to maintain acceptable control and are not recommended.

6.3 Altitude correction factors

Performance tables are based at sea level. Elevations other than sea level affect the performance of the unit. The decreased air density will reduce condenser capacity and reduce the unit's performance. Maximum allowable altitude is 1800meters.

6.4 Fouling factor

Fouling refers to the accumulation of unwanted material on solid surfaces, most often in an aquatic environment. The fouling material can consist of either living organisms (biofouling) or a non-living substance (inorganic or organic). Fouling is usually distinguished from other surface-growth phenomena in that it occurs on a surface of a component, system or plant performing a defined and useful function, and that the fouling process impedes or interferes with this function.

Other terms used in the literature to describe fouling include: deposit formation, encrustation, crudding, deposition, scaling, scale formation, slagging, and sludge formation. The last six terms have a more narrow meaning than fouling within the scope of

the fouling science and technology, and they also have meanings outside of this scope; therefore, they should be used with caution.

Fouling phenomena are common and diverse, ranging from fouling of ship hulls, natural surfaces in the marine environment (marine fouling), fouling of heat-transfer components through ingredients contained in the cooling water or gases, and even the development of plaque or calculus on teeth, or deposits on solar panels on Mars, among other examples.

Foreign matter in the chilled water system will adversely affect the heat transfer capability of the evaporator, and could increase the pressure drop and reduce the water flow. To provide optimum unit operation, proper water treatment must be maintained. Refer to the table as following.

ALTITUDE (m)	Difference of water inlet and outlet temp. (°C)	Fouling Factor							
		0.018 m ² . °C /kW		0.044 m ² . °C /kW		0.086 m ² . °C /kW		0.172 m ² . °C /kW	
		C	P	C	P	C	P	C	P
Sea level	3	1.036	1.077	1.019	1.076	0.991	0.975	0.963	0.983
	4	1.039	1.101	1.022	1.080	0.994	0.996	0.971	0.984
	5	1.045	1.105	1.028	1.086	1.000	1.000	0.977	0.989
	6	1.051	1.109	1.034	1.093	1.006	1.004	0.983	0.994
600	3	1.024	1.087	1.008	1.064	0.980	0.984	0.951	0.991
	4	1.027	1.111	1.011	1.068	0.983	1.005	0.959	0.992
	5	1.034	1.115	1.017	1.074	0.989	1.009	0.965	0.997
	6	1.043	1.115	1.026	1.084	0.998	1.009	0.973	0.999
1200	3	1.013	1.117	0.996	1.052	0.969	1.011	0.942	1.002
	4	1.015	1.118	0.998	1.055	0.971	1.012	0.948	1.003
	5	1.023	1.122	1.006	1.063	0.979	1.015	0.955	1.005
	6	1.031	1.125	1.015	1.072	0.987	1.018	0.962	1.007
1800	3	1.002	1.128	0.986	1.042	0.959	1.021	0.935	1.007
	4	1.005	1.129	0.989	1.045	0.962	1.022	0.941	1.010
	5	1.012	1.132	0.995	1.051	0.968	1.024	0.945	1.012
	6	1.018	1.134	1.001	1.058	0.974	1.026	0.949	1.014

Abbreviations:
 C: Cooling capacity
 P: Power input

7 Hydronic Performance

MC-SU75-RN8L-B

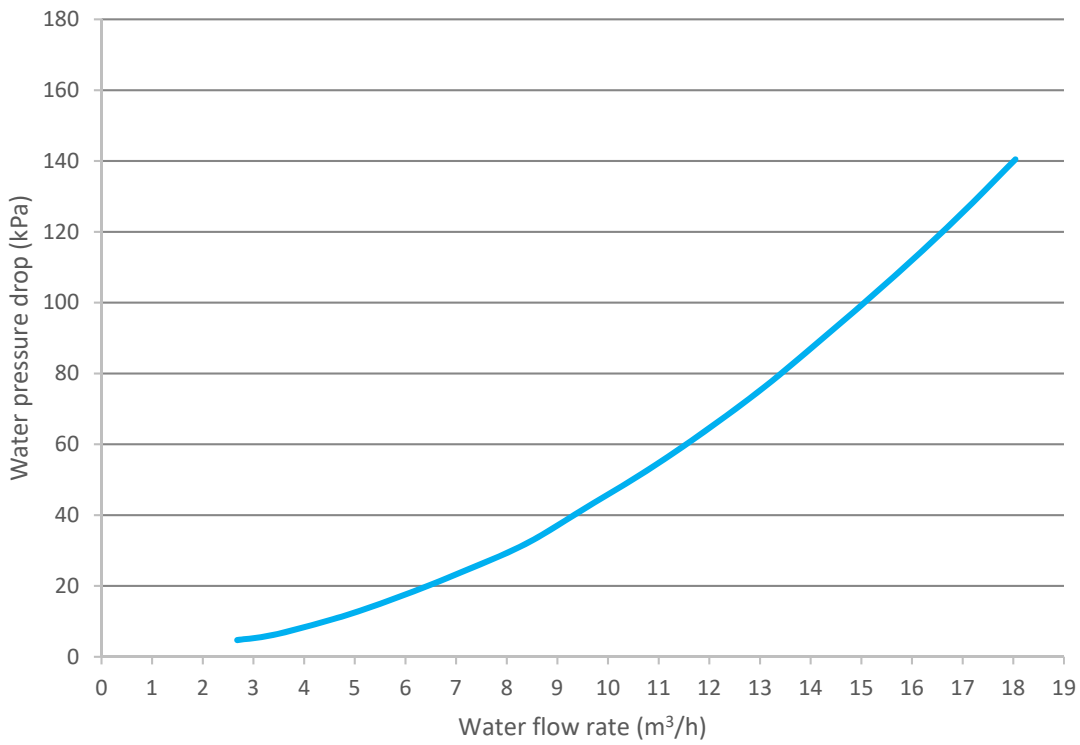

MC-SU90-RN8L-B

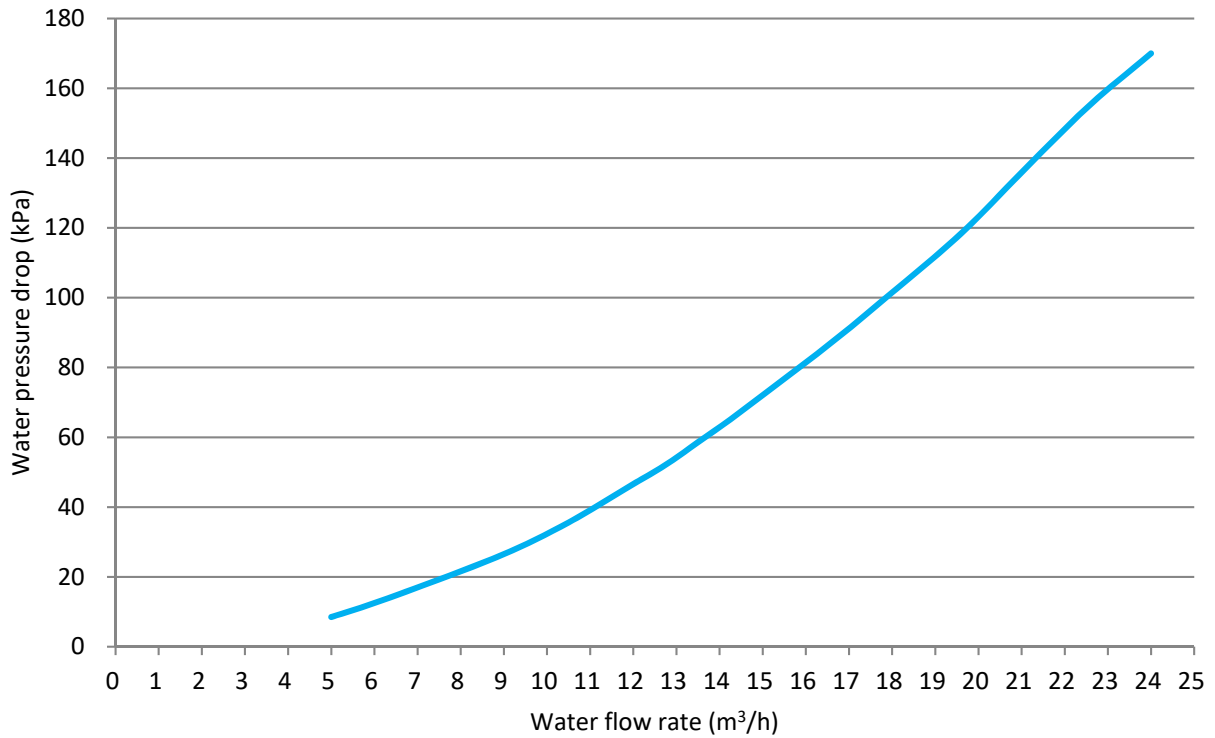

MC-SU140-RN8L-B

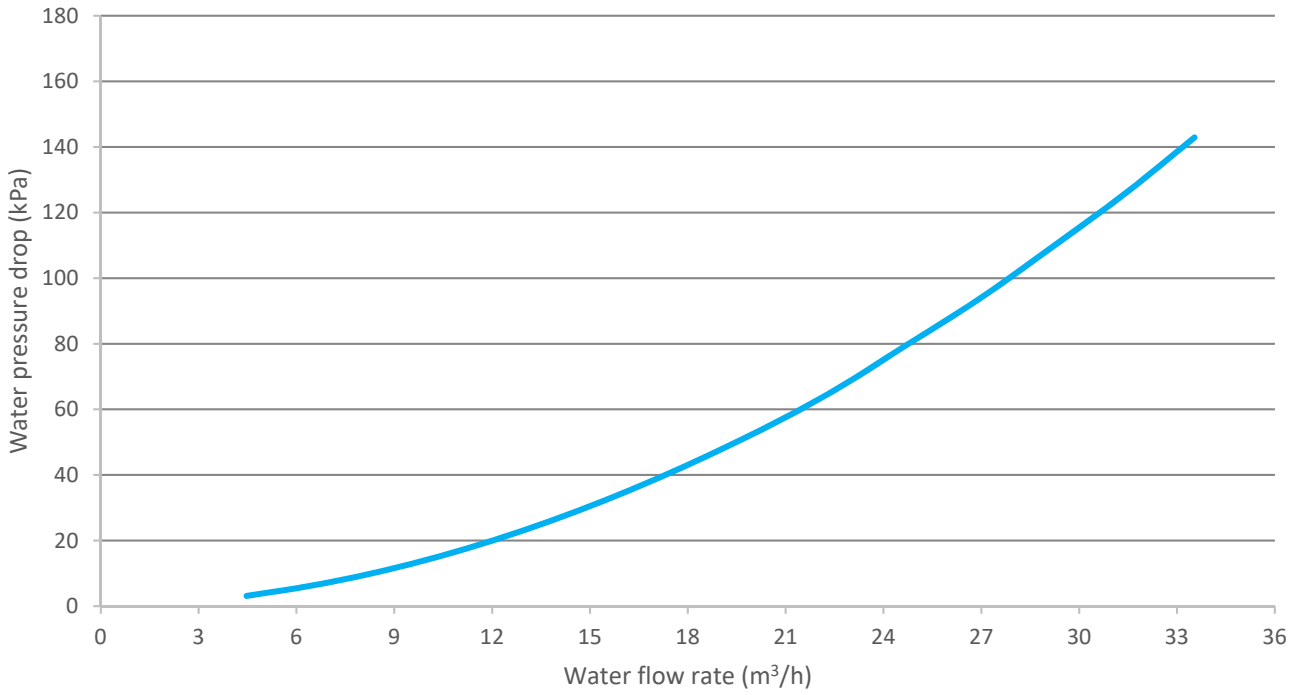

MC-SU180-RN8L-B

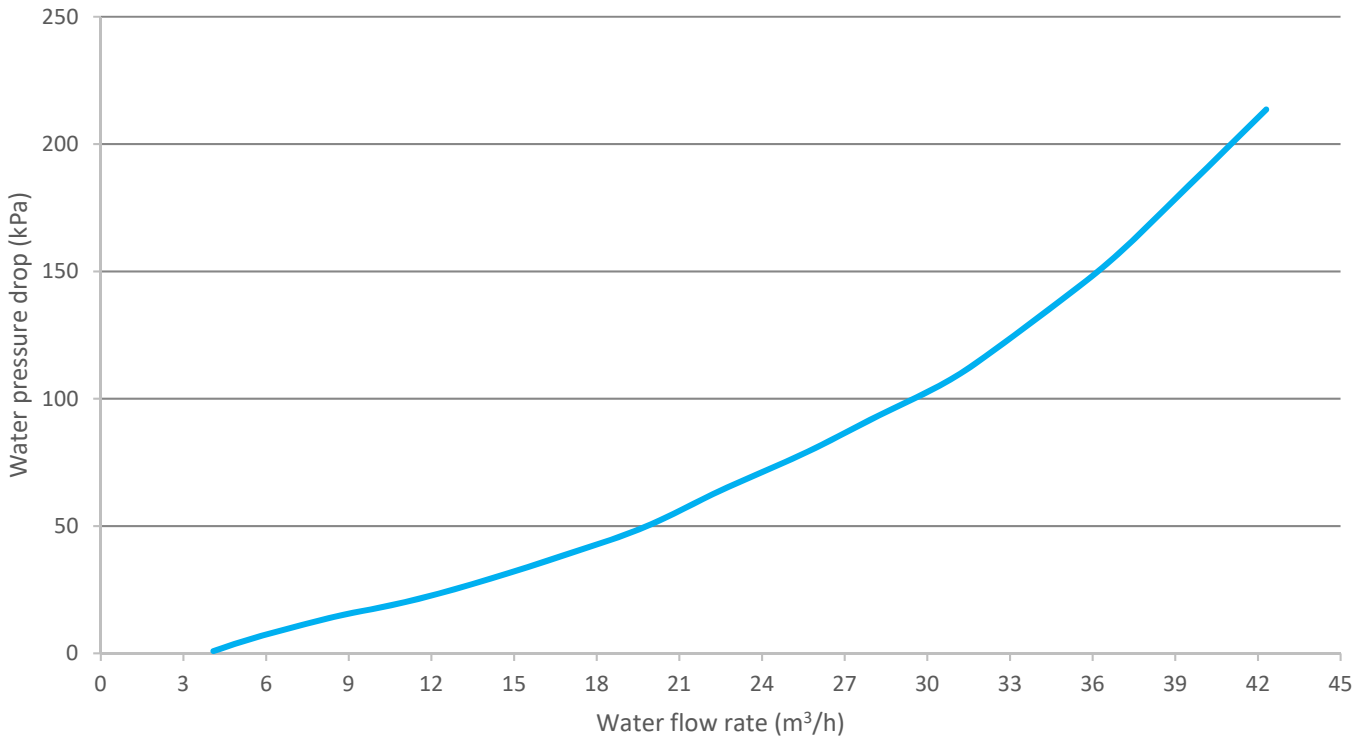

MC-SU75M-RN8L-B

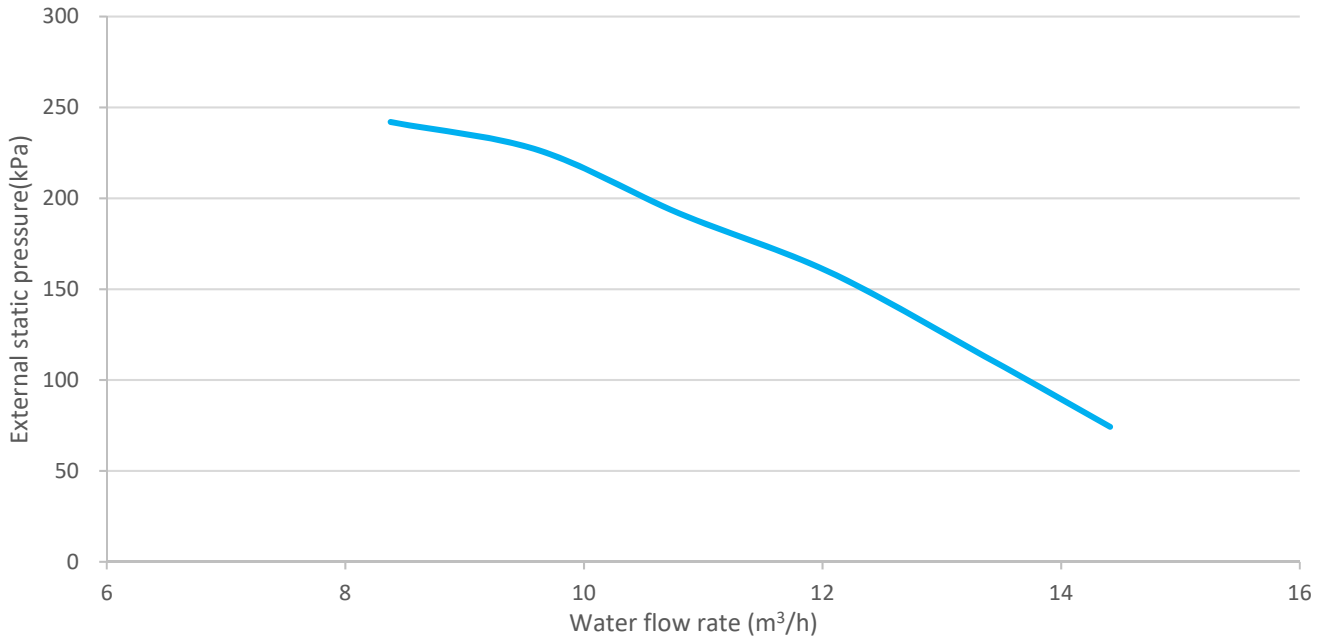

MC-SU90M-RN8L-B

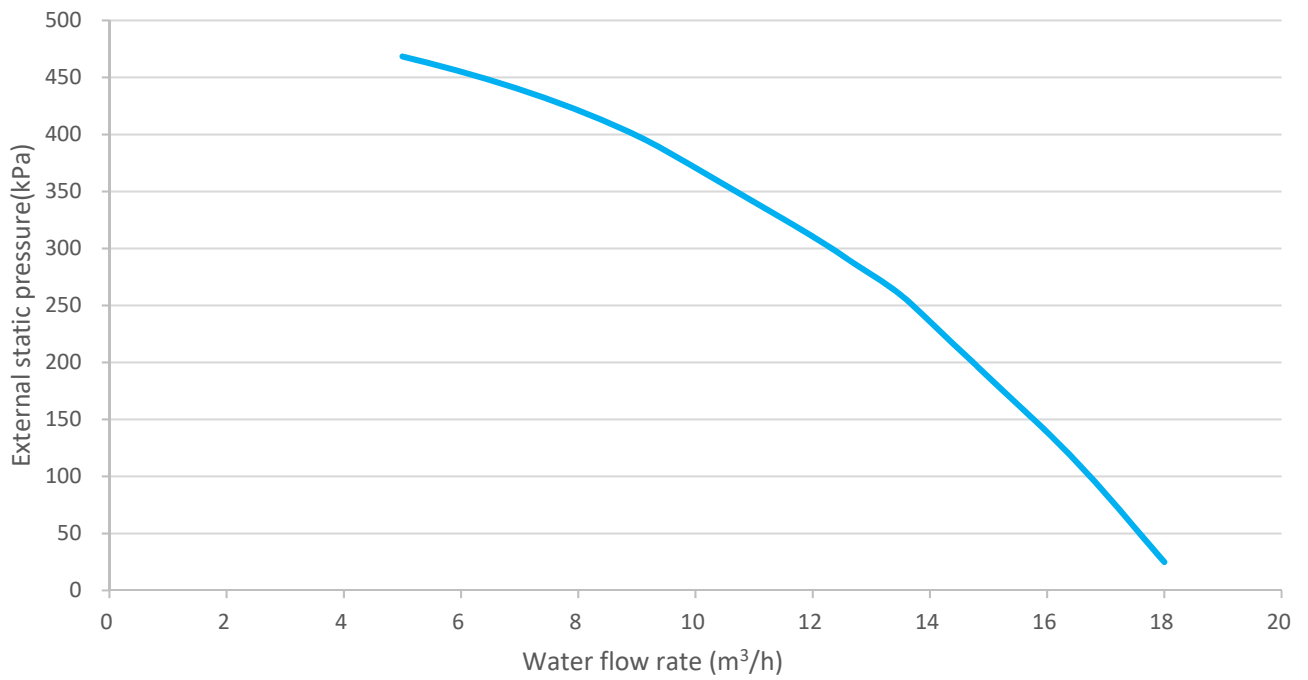

MC-SU140M-RN8L-B

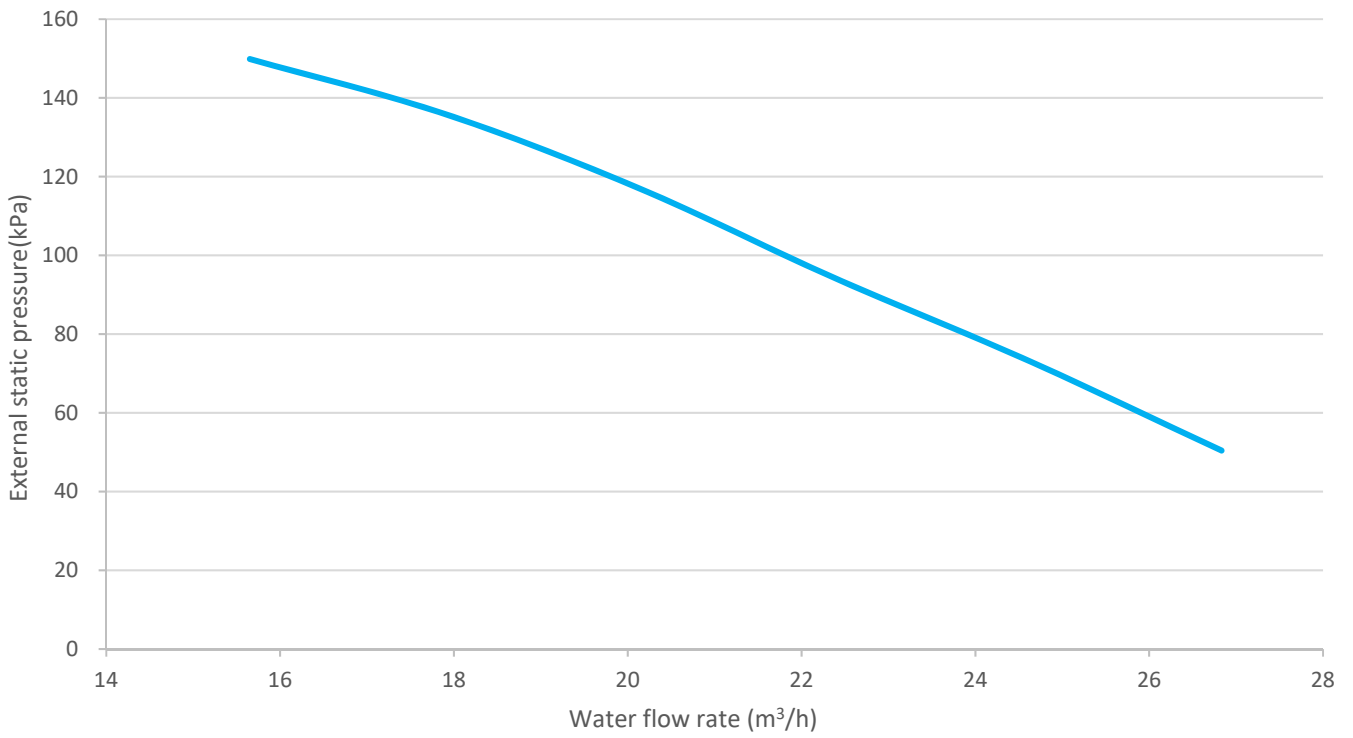

MC-SU180M-RN8L-B

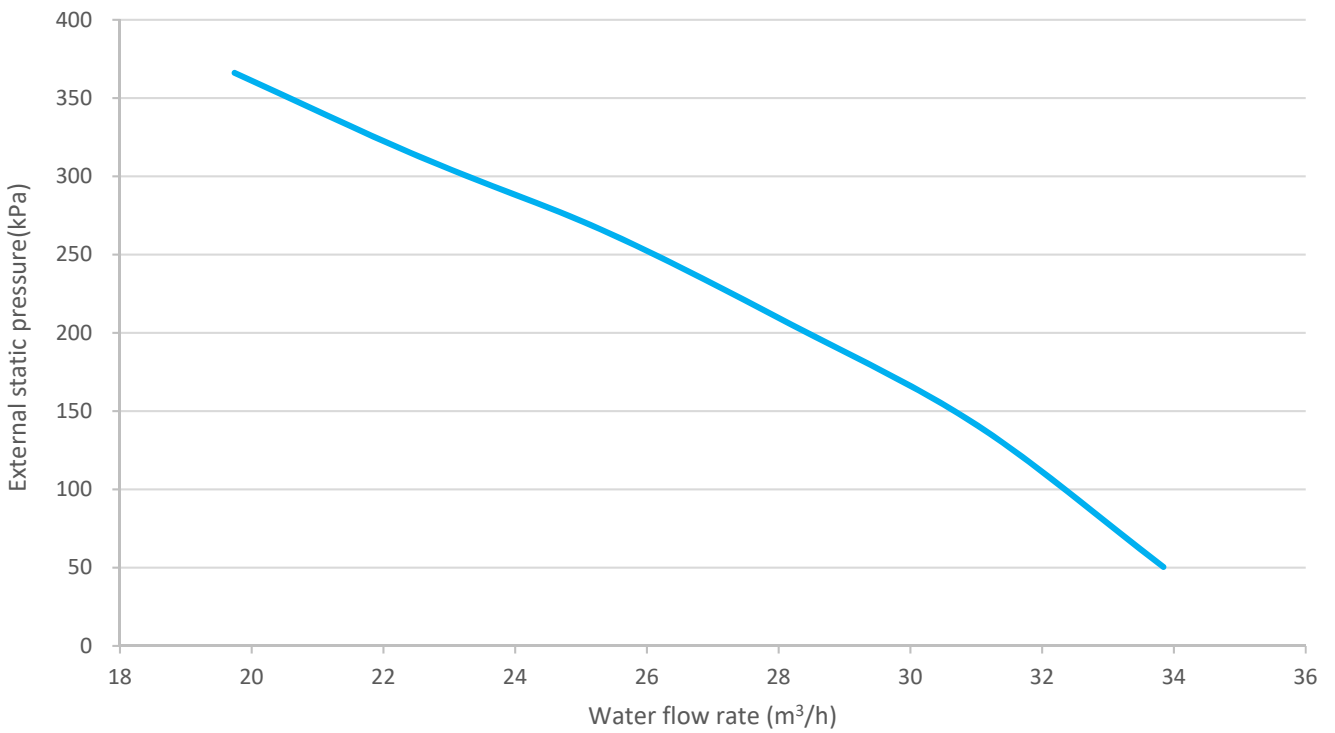

8 Octave Band Levels

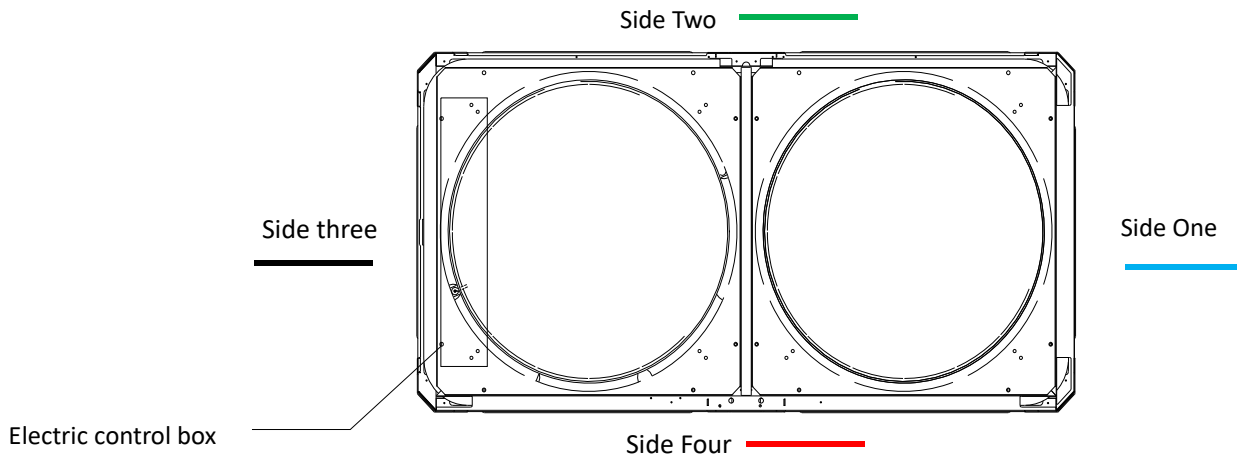

Test condition: Outdoor ambient temperature 35°C DB. EWT 12°C, LWT 7°C

MC-SU75-RN8L-B

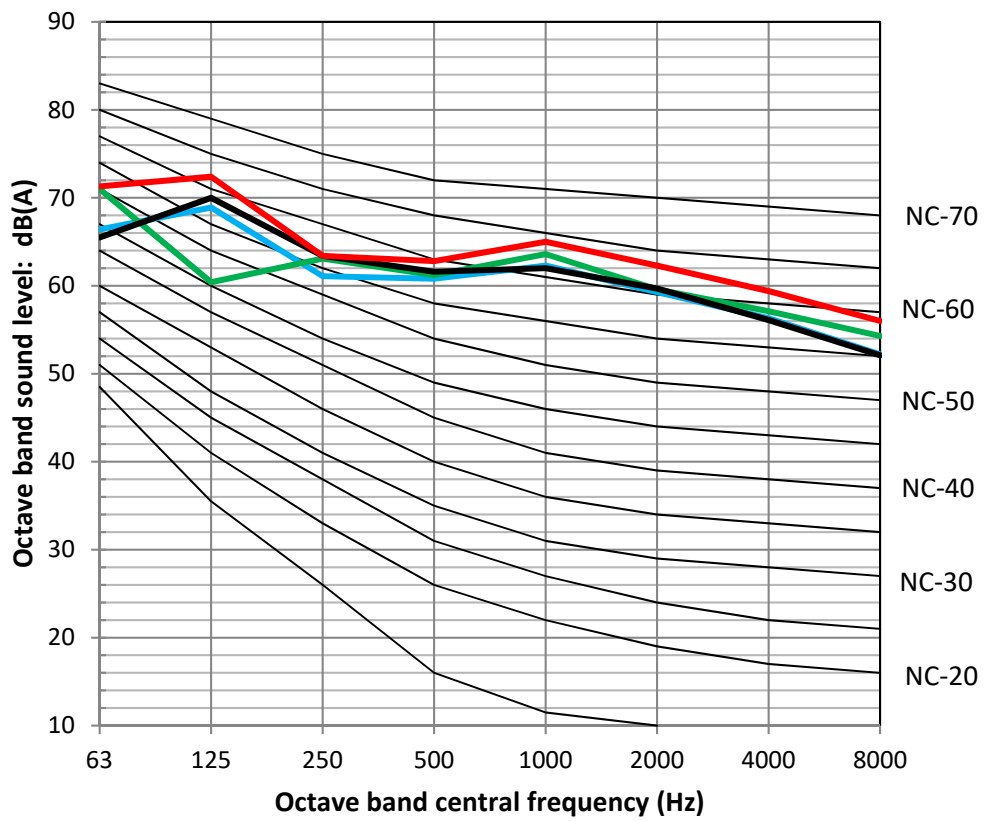

MC-SU75M-RN8L-B

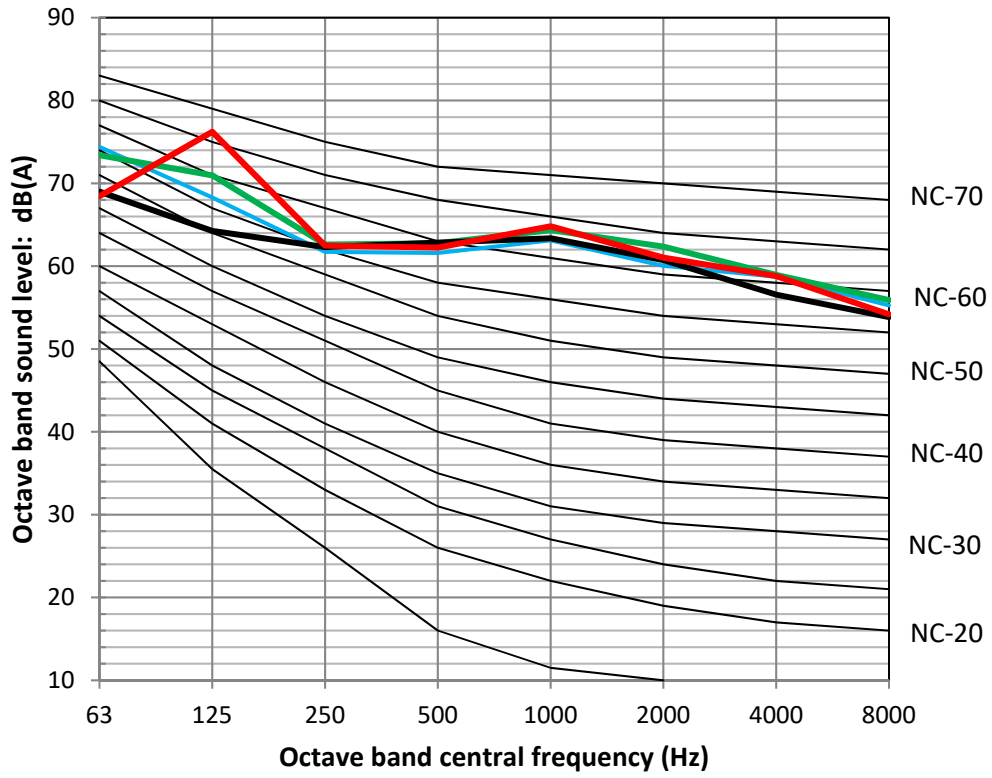

MC-SU90-RN8L-B

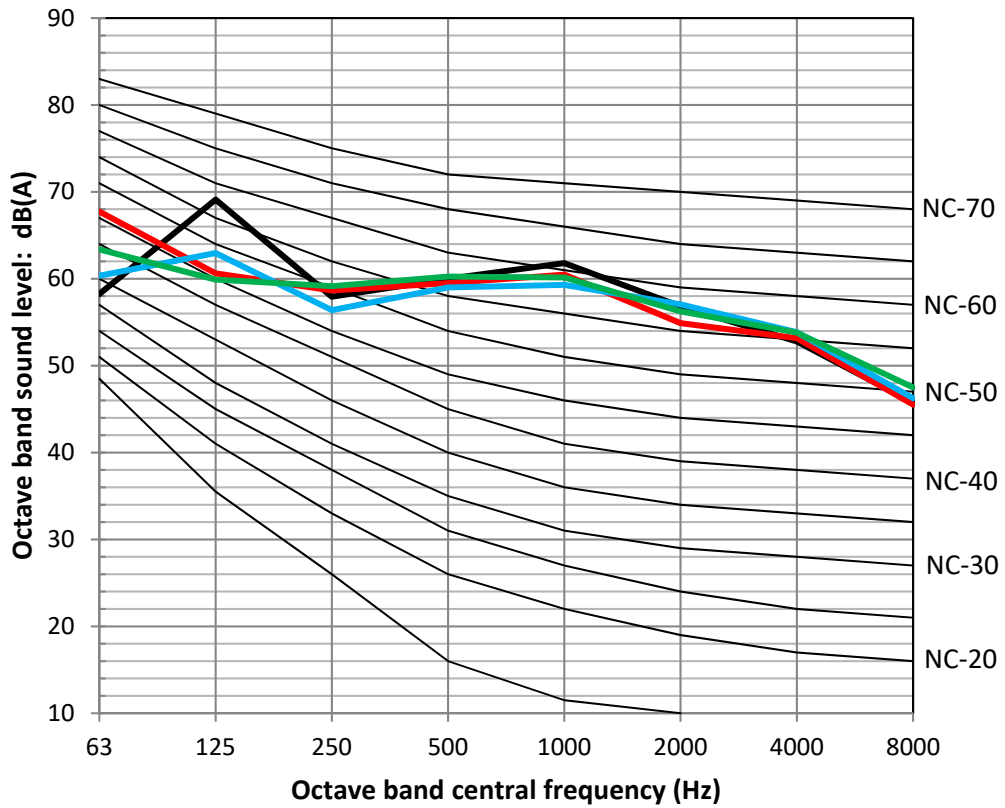

MC-SU90M-RN8L-B

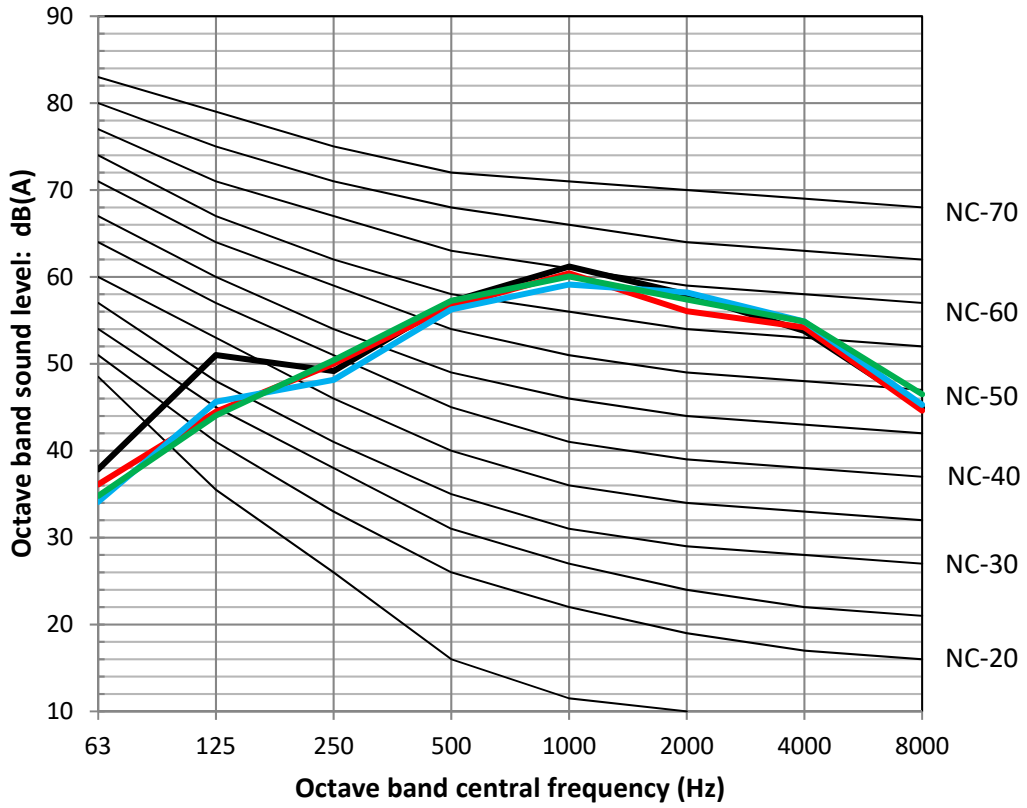

MC-SU140-RN8L-B

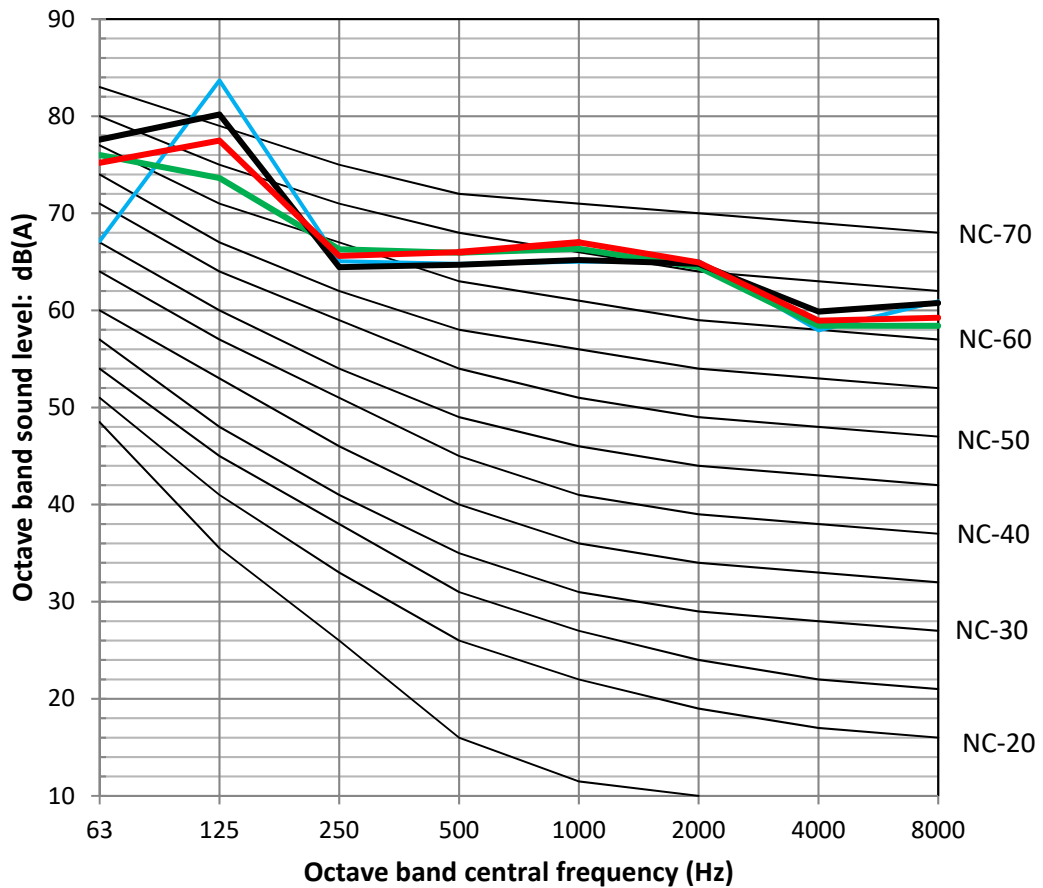

MC-SU140M-RN8L-B

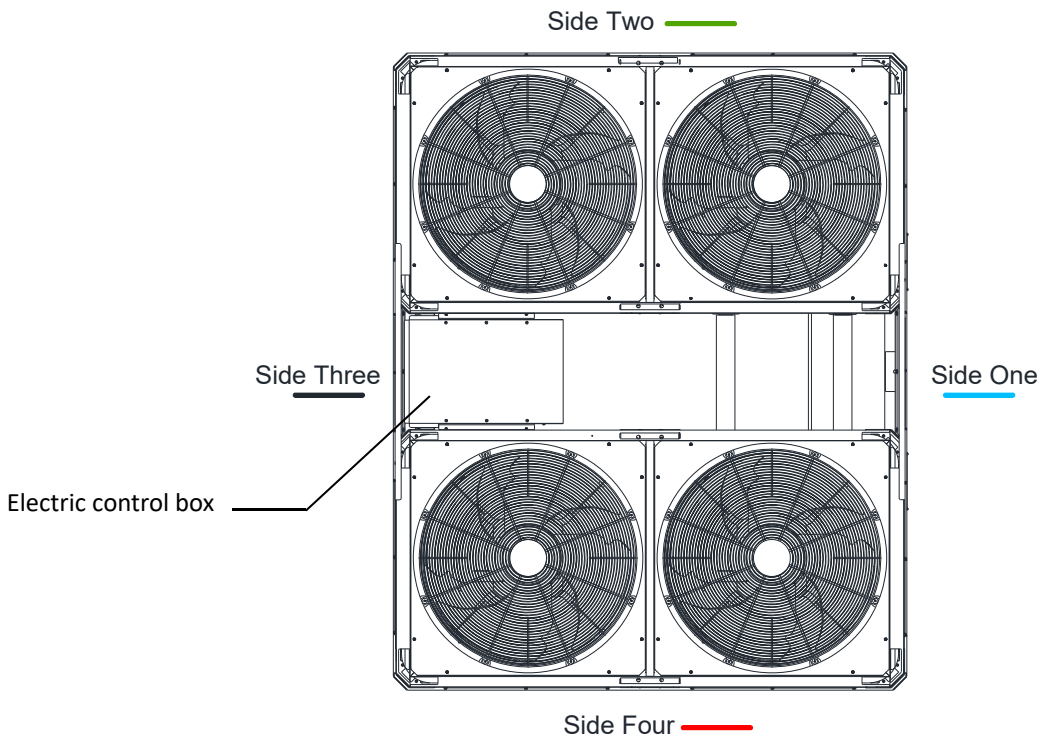
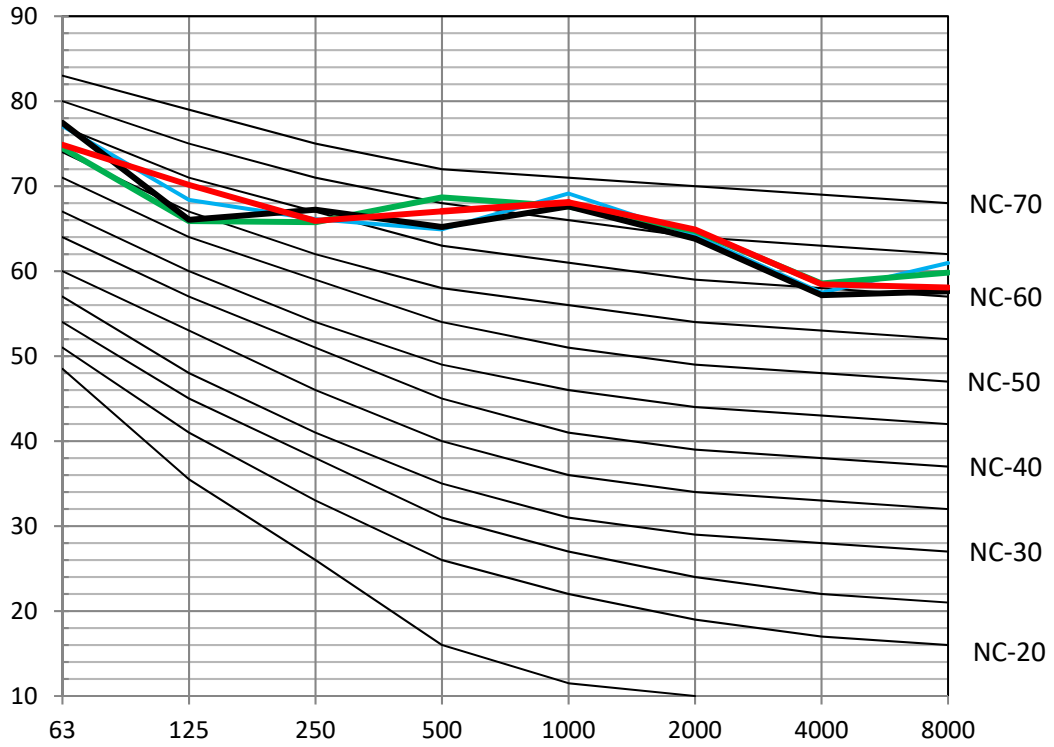

Test condition: Outdoor ambient temperature 35°C DB. EWT 12°C, LWT 7°C

MC-SU180-RN8L-B

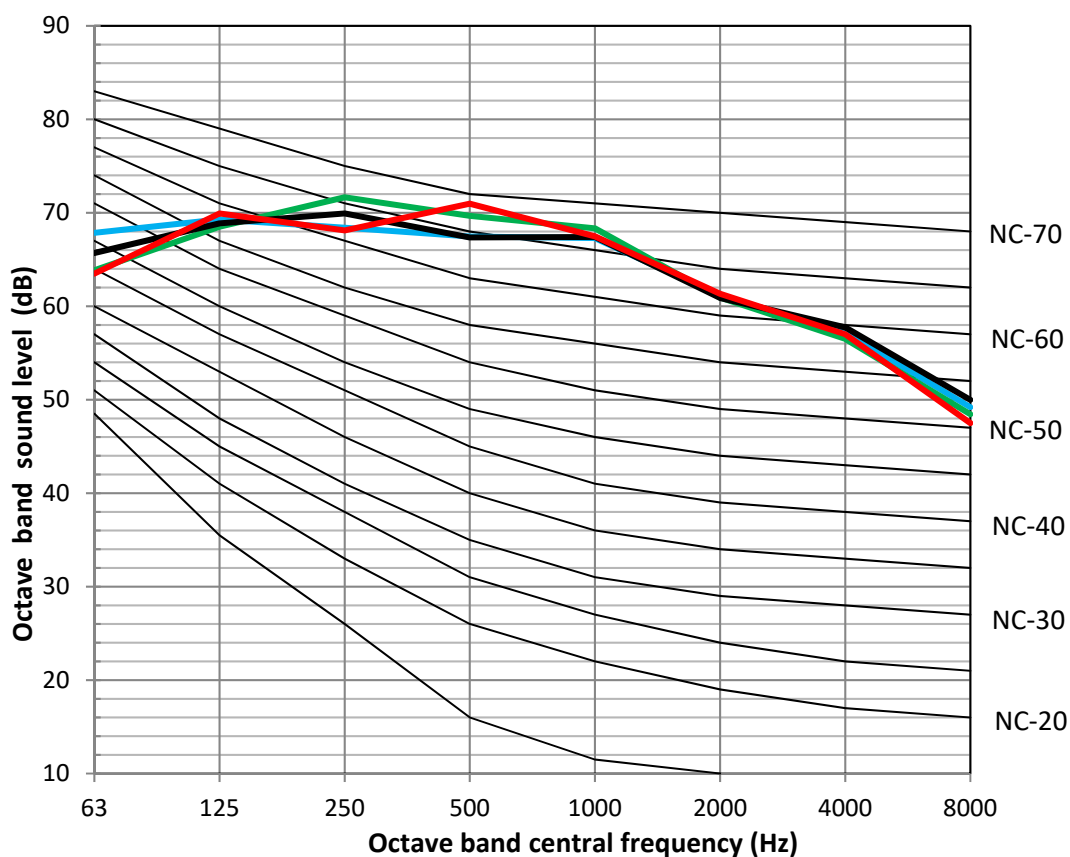

MC-SU180M-RN8L-B

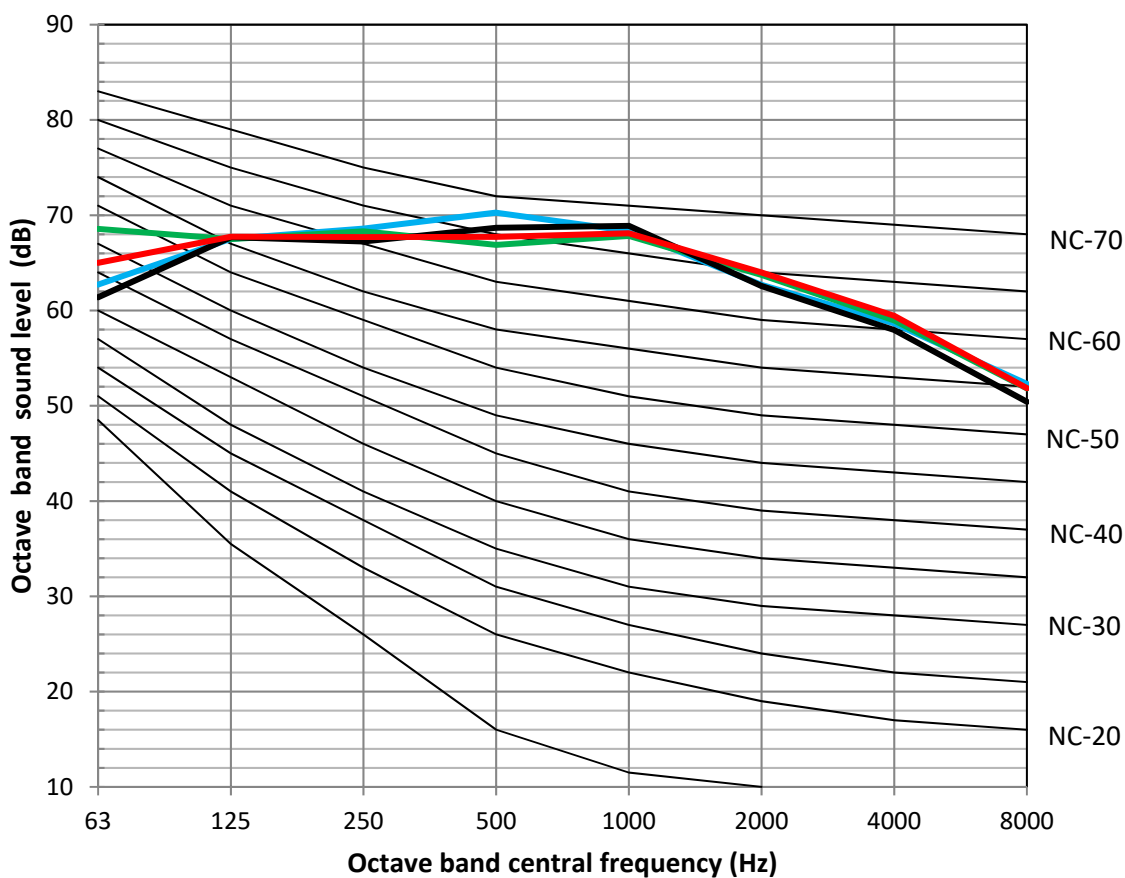

Part 3

User Interface Field Settings

1 User Interface Field Settings 45

1 User Interface Field Settings

1.1 Introduction

During installation, the unit's settings and parameters should be configured by the installer to suit the installation configuration, climate conditions and end-user preferences. The relevant settings are accessible and programmable through the SERVICE and PROJECT menu on the wired controller's user interface.

KJRM-120H2/BMWKO-E

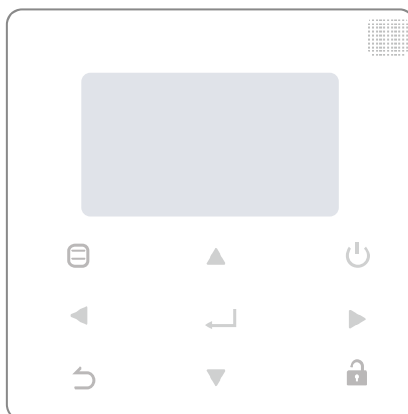

Icon	Function
	Enter the menu structure from the home page
	Navigate the cursor on the display/navigate in the menu structure/ adjust the settings
	Turn on or off the space operation mode
	Come back to the up level
	Long press for unlocking /locking the controller
	Go to the next step when programming a schedule in the menu structure / confirm a selection/enter a submenu in the menu structure

1.2 SERVICE MENU

1.2.1 Structure

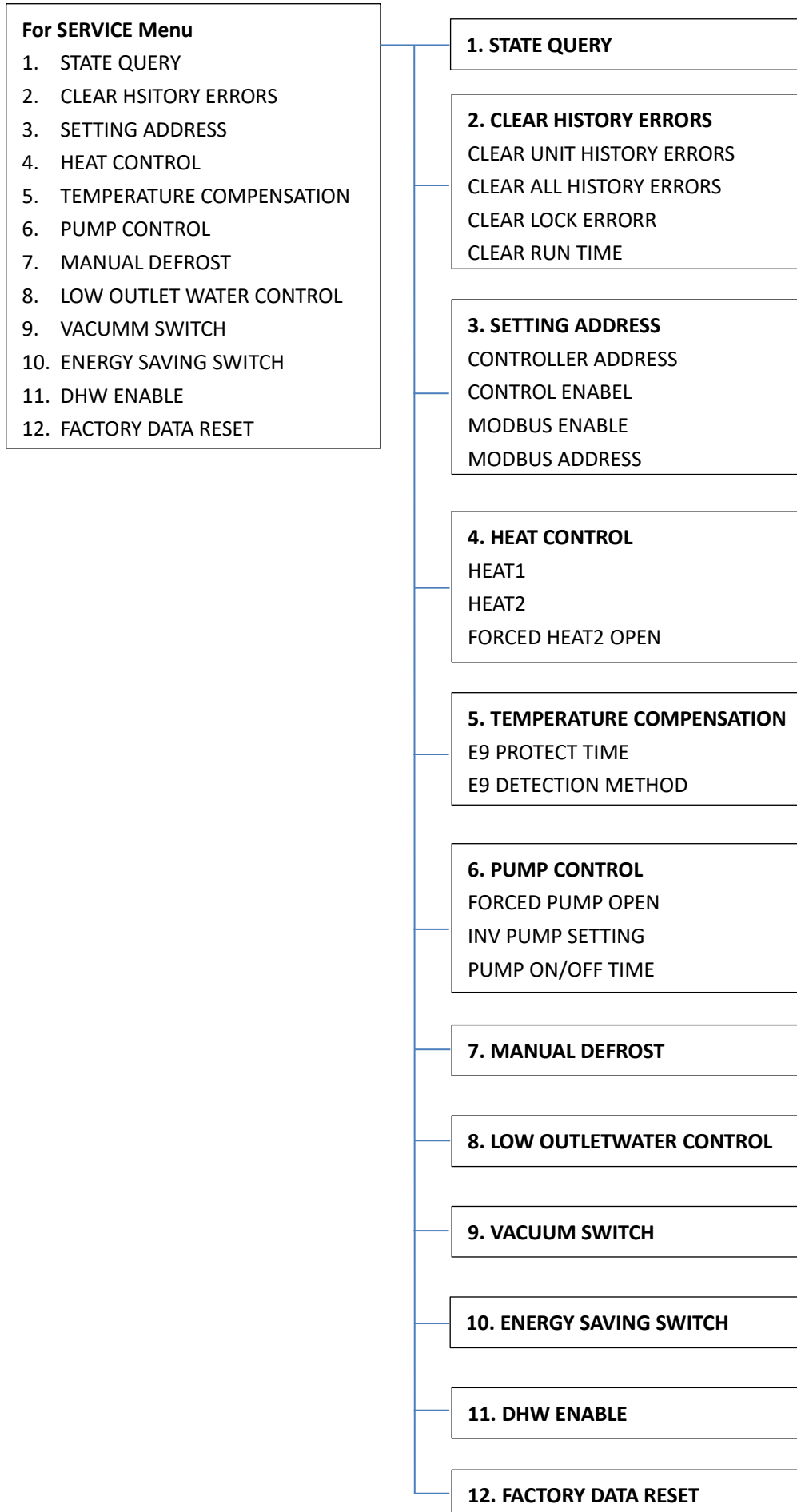

Aqua thermal



1.2.2 Service Menu

MENU > Service Menu

Service Menu allows installers to input the system configuration and set the system parameters. Enter the password, using ◀ ▶ to navigate between digits and using ▼ ▲ to adjust the numerical values, and then press ↵. The password is 234.

SERVICE MENU
PLEASE INPUT THE PASSWORD
0 0 0
OK ▼ ▲

The following pages will be displayed after putting the password.

SERVICE MENU
STATE QUERY
CLEAR HISTORY ERRORS
SETTING ADDRESS
HEAT CONTROL
OK 1/3 ▼ ▲

SERVICE MENU
TEMPERATURE COMPENSATION
PUMP CONTROL
MANUAL DEFROST
LOW OUTLET WATER CONTROL
OK 2/3 ▼ ▲

SERVICE MENU
VACUUM SWITCH
ENERGY SAVING SWITCH
DHW ENABLE
FACTORY DATA RESET
OK 3/3 ▼ ▲

1.2.3 State query

MENU > Service Menu > State query

SERVICE MENU
STATE QUERY
CLEAR HISTORY ERRORS
SETTING ADDRESS
HEAT CONTROL
OK 1/3 ▼ ▲

STATE QUERY allows installers to check the operation parameters. Press ◀ ▶ to select the address of units.

STATE QUERY
SELECT ADDRESS ◀ 07 ▶ #
ODU MODEL 130 kW
COMP FREQUENCY 50 Hz
COMP1 CURRENT 20 A
COMP2 CURRENT 20 A
BACK ▼ ▲

STATE QUERY
H-P PRESSURE 3.83 MPa
L-P PRESSURE 1.00 MPa
TP1 DISCHARGE TEMP 30 °C
TP2 DISCHARGE TEMP 30 °C
TH SUCTION TEMP -20 °C
OK 2/9 ▼ ▲

STATE QUERY
TZ TEMP -20°C
T3 TEMP -20°C
T4 TEMP -20°C
T6A TEMP 40°C
T6B TEMP 40°C
BACK 3/9 ▼ ▲

STATE QUERY
TFIN1 TEMP 60 °C
TFIN2 TEMP 60 °C
TDSH 30 °C
TSSH 15 °C
TCSH 15 °C
BACK 4/9 ▼ ▲

STATE QUERY
FAN1 SPEED 850 RPM
FAN2 SPEED 850 RPM
FAN3 SPEED 850 RPM
EXV A 1800 P
EXV B 1800 P
BACK 5/9 ▼ ▲

STATE QUERY
EXV C 1800P
Two TEMP 30°C
Two TEMP 30°C
Tw TEMP 30°C
TAF1 TEMP 30°C
BACK 6/9 ▼ ▲

STATE QUERY	
TAF2 TEMP	30 °C
T5 TEMP	30 °C
COMP TIME1	120 MIN
COMP TIME2	120 MIN
COMP TIME3	120 MIN
BACK	7/9

STATE QUERY	
COMP TIME	65535 H
FIX PUMP TIME	65535 H
INV PUMP TIME	65535 H
ODU SOFTWARE	V45
HMI SOFTWARE	V45
BACK	8/9

STATE QUERY	
DEFROSTING STATE	
00	01
02	03
04	05
06	07
08	09
10	11
12	13
14	15
E2 SOFTWARE V45	
END	
OK	9/9

Note:

1. Tz plate heat exchanger outlet temperature

T3 lowest temperature of condenser tube

T4 ambient temperature

T6A, T6B EVI plate heat exchanger refrigerant temperature

Tfin1, Tfin2 inverter module temperature

TDSH Discharge superheat temperature

TSSH Suction superheat temperature

TCSH Injection superheat temperature

Twi Unit water inlet temperature

Two Unit water outlet temperature

Tw Total water outlet temperature

Taf1 tank antifreeze temperature

Taf2 Water side antifreeze temperature

T5 Water tank temperature

2. For ODU SOFTWARE and HMI SOFTWARE, the version number will vary with product iterations.

1.2.4 Clear history errors

MENU > Service Menu > Clear history errors

SERVICE MENU	
STATE QUERY	
CLEAR HISTORY ERROR	
SETTING ADDRESS	
HEAT CONTROL	
OK	1/3

CLEAR HISTORY ERRORS is used to clear the history error codes and component operation time.

CLEAR UNIT HIS ERRS	
SELECT ADDRESS	◀ 07 ▶
DO YOU WANT TO CLEAR?	◀ YES ▶
OK	↕ ↔

CLEAR ALL HIS ERRS	
DO YOU WANT TO CLEAR?	◀ YES ▶
OK	↔

CLEAR LOCK ERR	
DO YOU WANT TO CLEAR?	◀ YES ▶
OK	↔

CLEAR RUN TIME	
SELECT ADDRESS	◀ 07 ▶
CLEAR COMP TIME?	◀ NO ▶
CLEAR FIX PUMP TIME?	◀ NO ▶
CLEAR INV PUMP TIME?	◀ NO ▶
OK	↕ ↔

1.2.5 Setting address

MENU > Service Menu > Setting address

SERVICE MENU
STATE QUERY
CLEAR HISTORY ERROR
SETTING ADDRESS
HEAT CONTROL
OK 1/3

SETTING ADDRESS is used to set whether the unit can be controlled by wired controller and through MDOBUS. **SETTING ADDRESS** can also enter by combining buttons pressing , for 3s.

CONTROLLER ADDRESS	◀ 10 ▶ #
CONTROL ENABEL	◀ NO ▶
MODBUS ENABLE	◀ NO ▶
MODBUS ADDRESS	◀ 10 ▶ #
OK	

CONTROLLER ADDRESS selects the unit address then we can check the parameters about this unit.

If **CONTROL ENABLE** sets as YES, it means the controller can set all the parameters; if **CONTROL ENABLE** sets as NO, it means the controller can only display the parameters.

If the chiller system access to MODBUS system, **MODBUS ENABLE** should be set as YES. Please note that in this case, **CONTROL ENABLE** should be also set as YES, otherwise the units cannot be controlled.

MODBUS ADDRESS set the controller address if the Modbus system is available.

1.2.6 Heat control

MENU > Service Menu > Heat control

SERVICE MENU
STATE QUERY
CLEAR HISTORY ERROR
SETTING ADDRESS
HEAT CONTROL
OK 1/3

HEAT CONTROL
HEAT1
HEAT2
FORCED HEAT2 OPEN
OK

HEAT1 means pipe electric heating in cooling/heating mode.

HEAT2 means tank electric heating in DHW mode.

HEAT1	
HEAT1 ENABLE	◀ NO ▶
TEMP-AUXHEAT1-ON	◀ 07 ▶ °C
TW. HEAT1-ON	◀ 25 ▶ °C
TW. HEAT1-OFF	◀ 45 ▶ °C
OK 1/2	

HEAT2	
ALL HEAT2 DISABLE	◀ YES ▶
SELECT ADDRESS	◀ 10 ▶ #
HEAT2-ENABLE	◀ NO ▶
T-HEAT2-DELAY	◀ 190 ▶ MIN
DT5-HEAT2-OFF	◀ 10 ▶ °C
OK 1/2	

HEAT2
T4-HEAT2-ON ◀ 10 ▶ °C
00 01 02 03 04 05 06 07
08 09 10 11 12 13 14 15
OK 2/2

FORCED HEAT2 OPEN
SELECTED ADDRESS ◀ 10 ▶ #
FORCED HEAT2 OPEN ◀ NO ▶
00 01 02 03 04 05 06 07
08 09 10 11 12 13 14 15
OK

TEMP-AUXHEAT1-ON sets the ambient temperature below which the pipe heater (field supplied) turns on.

When the leaving water temperature reaches TW. HEAT1-ON, the pipe electric heater (field supplied) turns on automatically.

When the leaving water temperature reaches TW. HEAT1-OFF, the pipe electric heater (field supplied) turns off automatically.

If the system is installed with tank booster heater, ALL HEAT2 DISABLE should be set as YES.

HEAT2-ENABLE sets the state of tank booster heater of SELECT ADDRESS.

T-HEAT2-DELAY sets the delay time for tank booster heater to turn on after the compressor starts.

DT5-HEAT2-OFF sets the temperature difference between the actual water temperature and setting temperature above which the tank booster heater turns off.

T4_HEAT2_ON sets the ambient temperature that tank booster heater turns on. (00~15 means unit address)

If **FORCED HEAT2 OPEN** is set as YES, when $T5 < T5S-1$, then tank electric heater turns on; when $T5 \geq T5S$, then tank electric heater off. (00~15 means unit address)

1.2.7 Temperature Compensation

MENU > Service Menu > Temperature Compensation

SERVICE MENU
TEMPERATURE COMPENSATION
PUMP CONTROL
MANUAL DEFROST
LOW OUTLET WATER CONTROL
OK 2/3

With the help of **TEMPERATURE COMPENSATION**, water temperature will automatically change as outside air temperature changes. When outdoor air temperature increases/decreases, the heating load will decrease/increase and water temperature will decrease/increase automatically. When outdoor air temperature decreases/increases, the cooling load will decrease/increase and water temperature will increase/decrease automatically.

TEMP COMPENSATION
COOL MODE ENABLE ◀ YES ▶ °C
T4 COOL-1 ◀ 15 ▶ °C
T4 COOL-2 ◀ 08 ▶ °C
OFFSET-C ◀ 10 ▶ °C
OK 1/2

TEMP COMPENSATION
HEAT MODE ENABLE ◀ YES ▶ °C
T4 HEAT-1 ◀ 15 ▶ °C
T4 HEAT-2 ◀ 08 ▶ °C
OFFSET-H ◀ 10 ▶ °C
OK 2/2

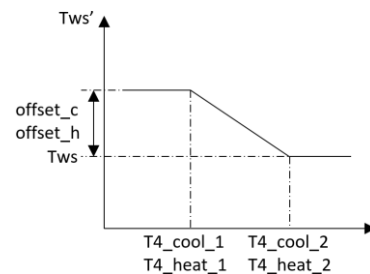

T4 COOL-1, T4 COOL-2 set the ambient temperature for cooling mode.

T4 HEAT-1, T4 HEAT-2 set the ambient temperature for heating mode.

Offset_c, Offset_h is the temperature difference between current water temperature and T4_cool_1, T4_heat_1 corresponding water temperature.

Aqua thermal



1.2.8 Pump Control

MENU > Service Menu > Pump Control

SERVICE MENU
TEMPERATURE COMPENSATION
PUMP CONTROL
MANUAL DEFROST
LOW OUTLET WATER CONTROL
OK 2/3

PUMP CONTROL
FORCED PUMP OPEN
INV PUMP SETTING
PUMP ON/OFF TIME
OK

FORCED PUMP OPEN
SELECT ADDRESS ◀ 0 ▶ #
FORCED PUMP OPEN ◀ NO ▶
OK

INV PUMP SETTING
SELECT ADDRESS ◀ 07 ▶ #
SWITCH ON THE PUMP ◀ NO ▶
RATIO PUMP ◀ 100 ▶ #
OK

PUMP ON/OFF TIME
PUMP ON TIME ◀ 05 ▶ MIN
PUMP OFF TIME ◀ 05 ▶ MIN
OK

FORCED PUMP OPEN is used to control the fixed frequency pump (field supplied) operation.

INV PUMP SETTING is used to control the inverter water pump (field supplied) operation, the setting range of RATIO-PUMP is 30%-100%. It should ensure its flow meet the requirement of whole unit, otherwise the unit may be damaged.

PUMP ON TIME sets the pump operation time after the unit stops.

If PUMP OFF TIME sets as 0, the pump will run all the time. Otherwise, the pump will operate intermittently according to the PUMP ON TIME and PUMP OFF TIME setting.

	Set range	Default value	Adjustment range
PUMP ON TIME	5~60min	5	5
PUMP OFF TIME	0~60min	0	5

1.2.9 Manual Defrost

MENU > Service Menu > Manual Defrost

SERVICE MENU
TEMPERATURE COMPENSATION
PUMP CONTROL
MANUAL DEFROST
LOW OUTLET WATER CONTROL
OK 2/3

MANUAL DEFROST
SELECT ADDRESS ◀ 07 ▶ #
MANUAL DEFROST ◀ NO ▶
OK

MANUAL DEFROST can force the unit to enter the defrost mode manually.

If the external unit successfully enters the defrost mode after the “MANUAL DEFROST” is turned on, the defrost icon  will be displayed at homepage of the wired controller.

1.2.10 Low outlet water temperature control

MENU > Service Menu > Low outlet water temperature control

SERVICE MENU
TEMPERATURE COMPENSATION
PUMP CONTROL
MANUAL DEFROST
LOW OUTLET WATER CONTROL
OK 2/3

At this page, the historical minimum water outlet temperature setting (setting range 0-20°C) can be viewed.

LOW OUTLET WATER CTRL	
MIN TEMP FOR COOL	◀ 50°C ▶
HISTORICAL SETTING	
04/06/2020 11:30A	5°C
04/06/2020 11:30A	5°C
04/06/2020 11:30A	5°C
OK	

MIN TEMP FOR COOL sets the lowest water temperature for cooling mode. Please notice that When the setting temperature is less than 5°C, antifreeze liquid should be added in the water system.

LOW OUTLET WATER CONTROL	
The setting temp is below 5 degree please confirm whether it is an antifreeze system?	
OK	

1.2.11 Vacuum switch

MENU > Service Menu > Vacuum switch

SERVICE MENU
VACUUM SWITCH
ENERGY SAVING SWITCH
DHW ENABLE
FACTORY DATA RESET
OK 3/3

VACUUM SWITCH	
VACUUM SWITCH	◀ NO ▶
OK	

VACUUM SWITCH is used for vacuuming.

1.2.12 Energy saving mode

MENU > Service Menu > Energy saving mode

SERVICE MENU
VACUUM SWITCH
ENERGY SAVING SWITCH
DHW ENABLE
FACTORY DATA RESET
OK 3/3

ENERGY SAVING SWITCH	
SAVING SWITCH	◀ 80% ▶
HISTORICAL SETTING	
04/06/2020 11:30A	80%
04/06/2020 11:30A	80%
04/06/2020 11:30A	80%
OK	

For projects with temporary electricity supply restrictions, the outdoor unit supports 7 levels of energy management which

Aqua thermal

can be set to output 40-100% capacity. It prevents tripping during electricity supply restriction conditions and remains system continue to operate. The historical energy saving switch setting can be viewed.

1.2.13 DHW ENABLE

MENU > Service Menu > DHW ENABLE

Domestic hot water function can be customized.

DHW ENABLE	
DHW ENABLE	◀ NO ▶
OK	▶◀

1.2.14 Factory data reset

MENU > Service Menu > Factory data reset

Factory data reset is used to reset all the data to the factory default setting.

FACTORY DATA RESET	
DO YOU WANT TO RESET?	◀ YES ▶
OK	▶◀

1.3 PROJECT MENU

1.3.1 Structure

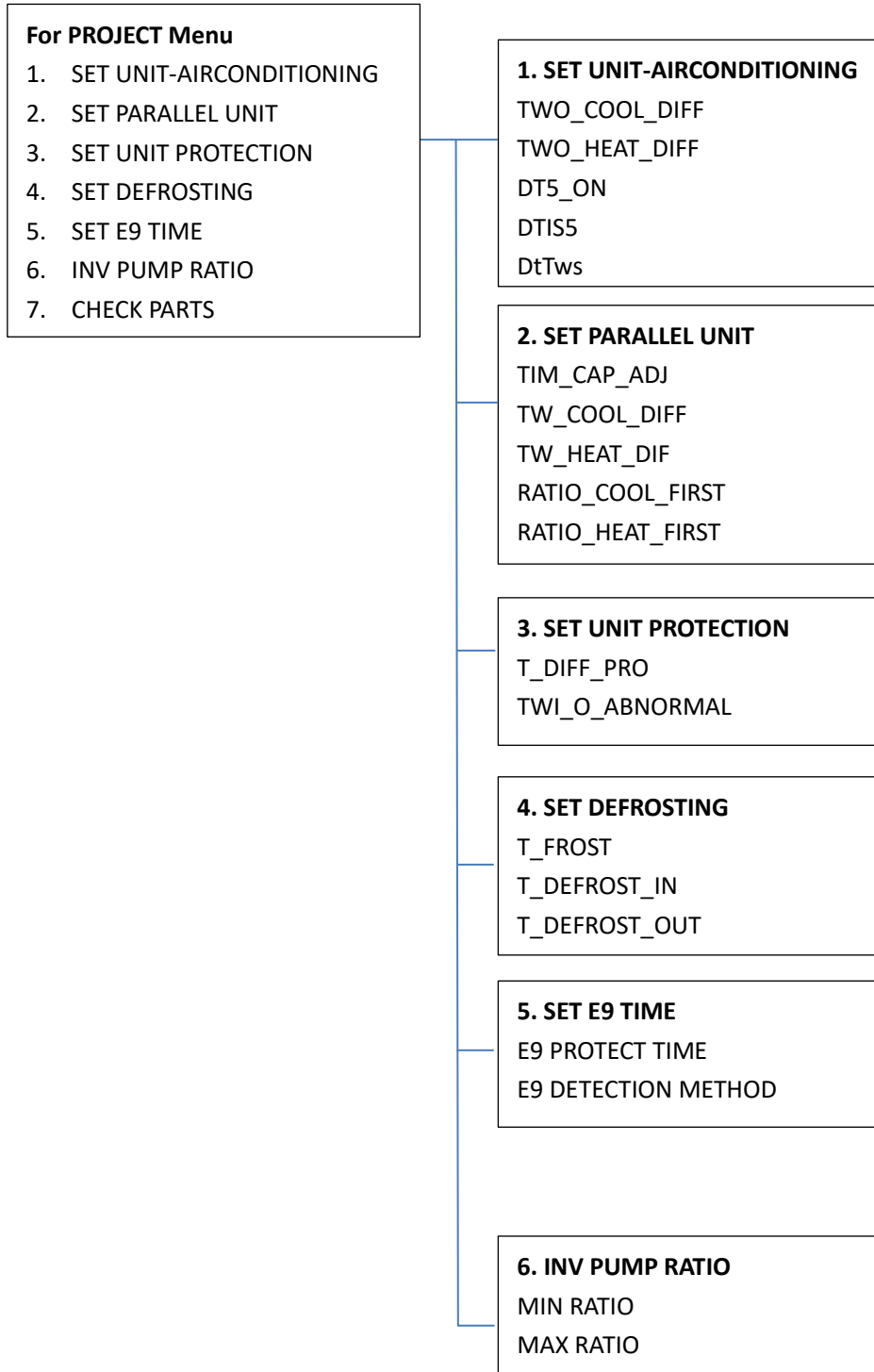

1.3.2 Project Menu

MENU > Project Menu

Project Menu allows installers to input the system configuration and set the system parameters. Enter the password, using ◀ ▶ to navigate between digits and using ▼ ▲ to adjust the numerical values, and then press **OK**. The password is 9877.

PROJECT MENU	
PLEASE INPUT THE PASSWORD	
0 0 0 0	
OK	▼ ▲

The following pages will be displayed after putting the password.

PROJECT MENU	
SET UNIT AIRCONDITIONING	
SET PARALLEL UNIT	
SET UNIT PROTECTION	
SET DEFROSTING	
OK	1/2 ▼

PROJECT MENU	
SET E9 TIME	
INV PUMP RATIO	
CHECK PARTS	
OK	2/2 ▼

1.3.3 SET UNIT-AIRCONDITIONING

MENU > Project Menu > SET UNIT-AIRCONDITIONING

SET UNIT	
TWO_COOL_DIFF	◀ 2 ▶ °C
TWO_HEAT_DIFF	◀ 2 ▶ °C
DT5_ON	◀ 8 ▶ °C
DTIS5	◀ 10 ▶ °C
DtTws	◀ 1 ▶ °C
OK	▼ ▲

TWO_COOL_DIFF sets the minimum temperature difference between the leaving water temperature (Two) and the leaving water set temperature (TwoS) above which the unit will start for cooling mode. When $Two - TwoS \geq TWO_COOL_DIFF$, unit starts. When $TwoS - Two \geq 2$ lasts for 5s, unit stops.

TWO_HEAT_DIFF sets the minimum temperature difference between the leaving water temperature (Two) and the leaving water set temperature (TwoS) above which the unit will start for heating mode. When $TwoS - Two \geq TWO_HEAT_DIFF$, unit starts. When $Two - TwoS \geq 2$ lasts for 5s, unit stops.

If unit is customized with the DHW function, when $TempW_heat_Min_n \leq T5 < \min(T5S, TempW_heat_Max_n) - DT5_ON$ and $Two < \min(T5S, TempW_heat_Max_n) - 2$, then DHW mode is on.

Note:

The value of $TempW_heat_Min_n$, $T5S$, $TempW_heat_Max_n$ are related to the ambient temperature, which are already fixed in the program.

T5 means the water tank temperature

T5S means the setting temperature of DHW mode

The target leaving water temperature of DHW mode is $Twos = T5S + DT1S5$. If $Two > TempW_heat_Max_n$, then DHW mode is off.

DtTws is reserved.

1.3.4 SET PARALLEL UNIT
MENU > Project Menu > SET PARALLEL UNIT

SET PAPALLEL UNIT	
TIM_CAP_ADJ	◀ 180 ▶ S
TW_COOL_DIFF	◀ 2 ▶ °C
TW_HEAT_DIFF	◀ 2 ▶ °C
RATIO_COOL_FIRST	◀ 0 ▶ %
RATIO_HEAT_FIRST	◀ 50 ▶ %
OK	↕ ⬅ ➡

TIM_CAP_ADJ sets the period of capacity adjustment

TW_COOL_DIFF sets the minimum temperature difference between the total leaving water temperature (Tw) and the total leaving water set temperature (TwS) above which the unit will start for cooling mode. When $T_w - TwS \geq TW_COOL_DIFF + 1$, unit starts. When $TwoS - Tw \geq 2$ lasts for 5s, unit stops.

TW_HEAT_DIFF sets the minimum temperature difference between the total leaving water temperature (Tw) and the total leaving water set temperature (TwS) above which the unit will start for heating mode. When $TwS - Tw \geq TW_HEAT_DIFF + 1$, unit starts. When $Tw - TwS \geq 1$ lasts for 5s, unit stops.

RATIO_COOL_FIRST sets the number of initial startup units for cooling mode.

RATIO_HEAT_FIRST sets the number of initial startup units for heating mode.

1.3.5 SET UNIT PROTECTION
MENU > Project Menu > SET UNIT PROTECTION

SET UNIT PROTECTION	
T_DIFF_PRO	◀ 12 ▶ °C
TWI_O_ABNORMAL	◀ 2 ▶ °C
OK	↕ ⬅ ➡

T_DIFF_PRO set the absolute difference between entering water temperature (Twi) and leaving water temperature (Two). If $|T_{wi} - Two| \geq T_DIFF_PRO$, unit stops and error code P9 appears. When $|T_{wi} - Two| \leq 6$, error code disappears.

TWI_O_ABNORMAL sets the difference between entering water temperature (Twi) and leaving water temperature (Two). For cooling mode, if $Two - Twi \geq TWI_O_ABNORMAL$ and lasts for 20min, unit stops and error code PA appears. If $Two - Twi \leq TWI_O_ABNORMAL - 1$, error code disappears. For heating mode, if $Twi - Two \leq TWI_O_ABNORMAL$ and lasts for 20min, unit stops and error code PA appears. If $Two - Twi > 1 - TWI_O_ABNORMAL$, error code disappears.

Aqua thermal



1.3.6 SET DEFROSTING

MENU > Project Menu > SET DEFROSTING

SET DEFROSTING	
T_FROST	◀ 35 ▶ min
T_DEFROST_IN	◀ 0 ▶ °C
T_FROST_OUT	◀ 0 ▶ °C
OK	⬆ ⬇ ⬅

T_FROST sets the time between the end of the last defrost mode and the beginning of the next defrost mode.

T_DEFROST_IN sets the temperature for T3 of entering defrosting mode. When T3 reaches T_DEFROST_IN, unit enters defrosting mode.

T_FROST_OUT sets the temperature for T3 of exiting defrosting model. When T3 reaches T_DEFROST_OUT, unit exits defrosting mode.

1.3.7 DHW time setting (Customized)

MENU > Project Menu > SET DHW TIME

SET DHW TIME	
SELECT ADDRESS	◀ 07 ▶ #
COOL MAX TIME	◀ 08 ▶ h
COOL MIN TIME	◀ 0.5 ▶ h
HEAT MAX TIME	◀ 08 ▶ h
HEAT MIN TIME	◀ 0.5 ▶ h
OK	1/2 ⬆ ⬇ ⬅

SET DHW TIME	
DHW MIN TIME	◀ 0.5 ▶ h
DHW MAX TIME	◀ 08 ▶ h
OK	2/2 ⬆ ⬇ ⬅

COOL MAX TIME sets the maximum operation time for cooling mode when DHW requirement exists.

COOL MIN TIME sets the minimum operation time for cooling mode when DHW requirement exists.

HEAT MAX TIME sets the maximum operation time for heating mode when DHW requirement exists.

HEAT MIN TIME sets the minimum operation time for heating mode when DHW requirement exists.

DHW MIN TIME sets the minimum operation time for DHW mode.

DHW MAX TIME sets the maximum operation time for DHW mode.

1.3.8 SET E9 TIME

MENU > Project Menu > SET E9 TIME

SET E9 TIME	
E9 PROTECT TIME	◀ 10 ▶ S
E9 DETECTION METHOD	◀ 1 ▶ #
OK	⬆ ⬇ ⬅

E9 PROTECT TIME sets the delay time of water flow detection. When unit starts, water flow will not be detected until at least (2+ E9 PROTECT TIME/60) minutes have elapsed.

E9 DETECTION METHOD sets the method of water flow detection. If "1" is selected, the water flow switch is detected after

water pump starts. If “2” is selected, the water flow switch is both detected before and after the water pump starts.

1.3.9 INV PUMP RATIO

MENU > Project Menu > INV PUMP RATIO

INV PUMP RATIO	
MIN RATIO	◀ 70 ▶ %
MAX RATIO	◀ 100 ▶ %
OK	⬇ ⬅

MIN RATIO sets the minimum output ratio of inverter pump which is installed in the main water pipe.

MAX RATIO sets the maximum output ratio of inverter pump which is installed in the main water pipe.

1.3.10 CHECK PARTS

MENU > Project Menu > CHECK PARTS

State of different parts can be checked in this menu.

CHECK PARTS	
SELECT ADDRESS	◀ 07 ▶ #
FIX PUMP STATE	OFF
INV PUMP STATE	80%
FOUR-WAY VALVE	OFF
SV1 STATE	OFF
BACK	1/3 ⬇ ⬅

CHECK PARTS	
SV2 STATE	OFF
SV4 STATE	OFF
SV5 STATE	OFF
SV6 STATE	OFF
SV8A STATE	OFF
BACK	2/3 ⬇ ⬅

CHECK PARTS	
SV8B STATE	OFF
HEAT1 STATE	OFF
HEAT2 STATE	OFF
COIL VALVE	OFF
BACK	3/3 ⬇ ⬅

1.4 Parameters setting

Menu	Parameters	Setting range	Default value	Adjustment range
Service menu	TEMP_AUXHEAT_ON	0~10°C	5°C	1°C
	TW_HEAT1_ON	0~50°C	25°C	1°C
	TW_HEAT1_OFF	0~50°C	45°C	1°C
	T_HEAT2_DELAY	60~240min	90min	5min
	DT5_HEAT2_OFF	2~10°C	5°C	1°C
	T4_HEAT2_ON	-5~20°C	5°C	1°C
	T4_COOL_1	15~30°C	25°C	1°C
	T4_COOL_2	35~45°C	40°C	1°C
	OFFSET_C	0~15°C	10°C	1°C
	T4_HEAT_1	-10~10°C	2°C	1°C
	T4_HEAT_2	15~30°C	15°C	1°C
	OFFSET_H	0~30°C	10°C	1°C
	RATIO_PUMP	30%~100%	100%	5%
	PUMP ON TIME	5~60min	5min	5min
	PUMP OFF TIME	0~60min	0min	5min
	MIN TEMP FOR COOL	0~20°C	7°C	1°C
ENERGY SAVING SWITCH	40~100%	100%	10%	

Menu	Parameters	Setting range	Default value	Adjustment range	
Project menu	TWO_COOL_DIFF	1°C~5°C	2°C	1°C	
	TWO_HEAT_DIFF	1°C~5°C	2°C	1°C	
	TIM_CAP_ADJ	60~360s	80s	20s	
	TW_COOL_DIFF	1°C~5°C	2°C	1°C	
	TW_HEAT_DIFF	1°C~5°C	2°C	1°C	
	RATIO_COOL_FIRST	0~100%	50%	5%	
	RATIO_HEAT_FIRST	0~100%	50%	5%	
	T_DIFF_PRO	8~15°C	12°C	1°C	
	TWI_O_ABNORMAL	1~5°C	2°C	1°C	
	T_FROST	20~120 min	35 min	5min	
	T_DEFROST_IN	-5~5°C	0°C	1°C	
	T_FROST_OUT	-10~+10°C	0°C	1°C	
	E9 PROTECT TIME	2~20s	5s	1	
	E9 DETECTION METHOD	1~2	1	1	
	MIN RATIO	40~100%	75%	5%	
	MAX RATIO	70~100%	100%	5%	
	Project menu (customized with DHW)	dT5_ON	2~10°C	8°C	1°C
		dT1S5	5~20°C	10°C	1°C
COOL MIN TIME		0.5~24h	0.5h	0.5h	
COOL MAX TIME		0.5~24h	8h	0.5h	
HEAT MIN TIME		0.5~24h	0.5h	0.5h	
HEAT MAX TIME		0.5~24h	8h	0.5h	

Midea Building Technologies Division
Midea Group

Add.: Midea Headquarters Building, 6 Midea Avenue, Shunde, Foshan, Guangdong, China

Postal code: 528311

mbt.midea.com www.midea-group.com tsp.midea.com

Midea reserves the right to change the specifications of the product, and to withdraw or replace products without prior notification or public announcement.

Midea is constantly developing and improving its products.

