

## SINGLE PIECE AIR HANDLERS - 50 Hz

### FOR USE WITH SPLIT-SYSTEM COOLING & HEAT PUMPS

COOLING AND  
HEAT PUMP MODELS:  
F2RP024 THRU 060

## DESCRIPTION

This fan coil unit provides the flexibility for installation in any up-flow or horizontal application. These versatile models may be used for split-system cooling or heat pump operation. Compact cabinets along with return air options in both the upflow and horizontal positions allow this unit to fit into tight spaces such as attics, crawl spaces, and closets.

NOTE: For matching condensing units and performance data, refer to condenser technical guides.

## FEATURES

**CABINET** -The compact and sturdy cabinet is protected with a durable, attractive finish to prevent rust. The cabinet is also insulated to prevent cabinet sweating.

**BLOWERS** - Blowers are sized to circulate air both quietly and efficiently. The direct-drive, 3-speed motors provide a selection of air volume to match any application. Motor speeds may be selected via quick connect terminal at the motor. Slide-out blower/motor assemblies provide for easy servicing.

**COILS** - Using the latest in heat transfer technology, the rifled tube coil/aluminum fin coils produce high performance ratings and provide long lasting quality. The coils are capable of bottom return air in the upflow position, and right or left end return air in the horizontal position.

**ELECTRIC HEATERS** - Models providing up to 25kw of heat are available. Heaters can be field or factory installed. Electric heaters are available in both single and three phase.

**EASY INSTALLATION** - These fan coil units are designed to provide the lowest total installation cost. Accessible color coded control wiring, top and side power wiring knockouts, easy to install drain connections and electric heaters all combine to minimize installed cost on every job.

**CONTROL BOARD** - The control board is equipped with low voltage terminal strips for easy installation. The control board is also equipped with plug-in receptacles for the auxiliary heaters.

## ACCESSORIES

Refer to Price Manual for specific model numbers.

**VERTICAL SUSPENSION KIT** - The suspension kit is designed to be used with all sizes of blowers whenever the application requires vertical suspension of the unit.

**ELECTRIC HEATERS** - Models shown under Electrical Data include sequencers and temperature dual limit switches for safe, efficient operation. Circuit breakers are provided where shown.

**BOLT-ON THERMAL EXPANSION VALVE** - TXV kits are available for enhanced efficiency.

**HORIZONTAL DRAIN PAN** - The drain pan kit is designed for field conversion to Horizontal left or right applications.

**NO HEAT POWER KIT** - For all cool-only applications. Must be used when an Electric Heater Kit is not required.

# DIMENSIONS

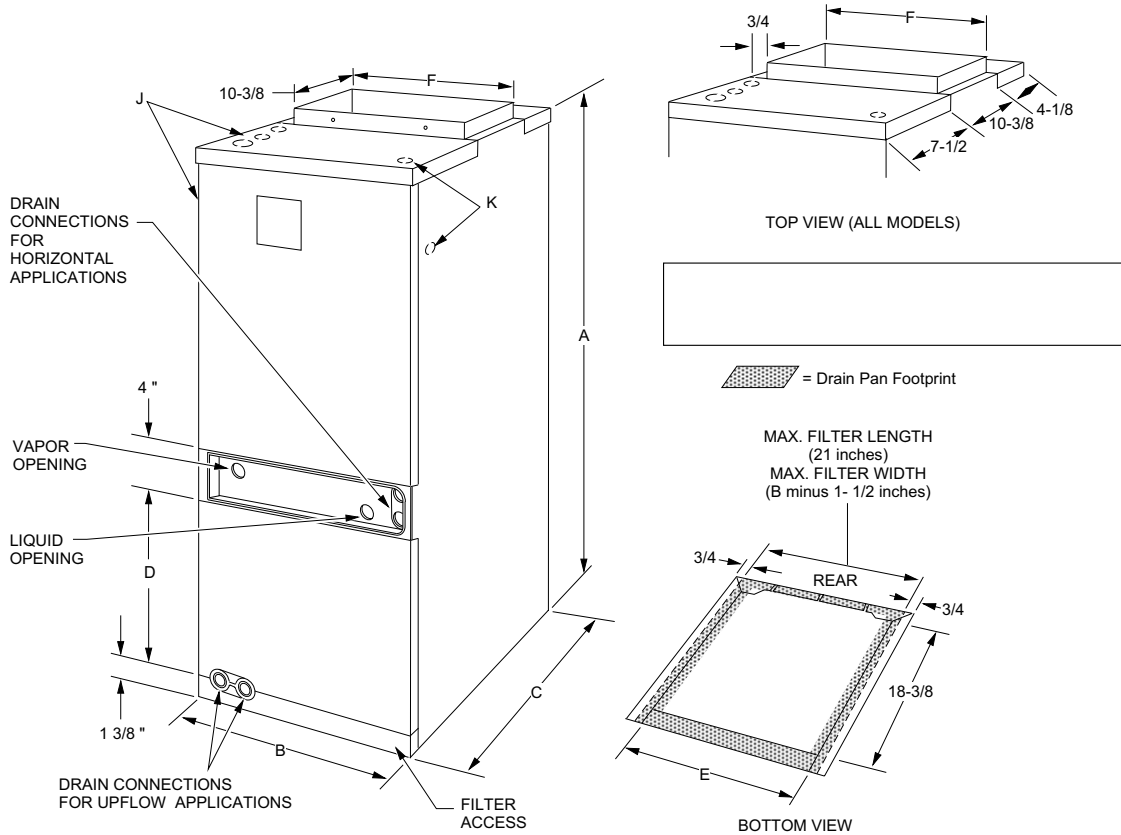

F2RP MODEL	DIMENSIONS						WIRING K.O.'S*		REFRIGERANT CONNECTIONS LINE SIZE	
	A	B	C	D	E	F	J	K	LIQUID	VAPOR
	HEIGHT	WIDTH	DEPTH				POWER	CONTROL		
024	40-3/4	18	22	12-1/8	14-7/8	16-1/2	7/8 (1/2)	7/8 (1/2)	3/8	5/8
036	40-3/4	21-1/2			18-3/8	20	1-3/8 (1)			3/4
048	50-3/4	24		17-3/8	20-7/8	22-1/2	7/8 (1/2)			7/8
060	50-3/4	24			20-7/8	27-1/2	1-3/8 (1), 1-23/32 (1-1/4)			7/8

\*NOTE: Actual conduit size is shown in brackets.

# COIL DATA

F2RP MODEL	APPLICA-TION	REFRIG. CONN. TYPE	STD. ORIFICE SIZE	FACE AREA (SQ. FT.)	ROWS DEEP	FINS PER INCH	COIL SLAB SIZE		TUBE GEOM-ETRY	TUBE DIA.	FIN TYPE	EXPAN-SION DEVICE
							H	W				
024	A/C & HP	Sweat	61	3.40	2	14	14	17.5	1 x .886	3/8	Enhanced	Orifice
036	A/C & HP		75	3.40	3	12	14	17.5				
048	A/C & HP		84	5.35	3	12	22	17.5				
060	A/C & HP		90	5.83	3	12	24	17.5				

\*\* Models only available with factory installed horizontal drain pan.

KW & MBH CONVERSIONS - FOR TOTAL POWER INPUT REQUIREMENT					
FOR	208V	OPERATION, MULTIPLY	240V	TABULATED KW & MBH BY	.751
	230V		240V		.918

\*\*ALTERNATE ELECTRIC HEAT STAGING FOR AUXILIARY HEAT DURING DEFROST

Defrost Output (66) Connected To	Heater Size (208 / 240 V)		
	W <sub>1</sub>	7.5 KW 3.8	10 - 20 KW 3.8 / 5
W <sub>2</sub>	5.6 7.5	7.5 / 10	11.3 / 15

Adjust values in Table above when used.

## COOLING CAPACITY

BLOWER MODEL	RATED CFM/MH	ENTERING AIR °F (Dry / Wet Bulb)	ENTERING AIR °C (Dry / Wet Bulb)	MBH @ Evaporator Temperature and Corresponding Pressure °C / PA (°F / PSIG)			
				1.7 / 427	4.4 / 476	7.2 / 528	10.0 / 584
				35 / 61.5	40 / 68.5	45 / 76.0	50 / 84.0
<b>UPFLOW / HORIZONTAL POSITIONS ONLY</b>							
F2RP024N93	830/1411	85 / 72	29 / 22	36.3	33.0	29.5	25.6
		80 / 67	27 / 19	33.4	30.2	26.7	23.1
		75 / 62	24 / 17	27.4	24.3	21.0	17.7
		70 / 57	21 / 14	22.2	19.3	16.2	12.6
F2RP036N93	1250/2125	85 / 72	29 / 22	53.4	48.6	43.4	38.3
		80 / 67	27 / 19	42.8	37.8	33.1	28.2
		75 / 62	24 / 17	33.4	28.1	30.6	22.8
		70 / 57	21 / 14	28.7	26.5	24.5	22.8
F2RP048N93	1600/2720	85 / 72	29 / 22	100.5	86.4	72.0	56.8
		80 / 67	27 / 19	80.4	67.5	55.0	42.1
		75 / 62	24 / 17	62.7	49.9	40.7	34.0
		70 / 57	21 / 14	53.9	47.2	40.7	34.0
F2RP060N93	1850/3145	85 / 72	29 / 22	119.9	101.0	82.0	62.2
		80 / 67	27 / 19	96.0	79.2	62.6	45.8
		75 / 62	24 / 17	74.8	58.6	46.2	37.0
		70 / 57	21 / 14	64.3	55.4	46.2	37.0

## LIMITATIONS

These units must be wired and installed in accordance with all national and local safety codes. Voltage limits are as follows:

Air flow must be within the minimum and maximum limits approved for electric heat, evaporator coils and outdoor units.

Normal Operating Voltage Range\* | 198 - 250

\* Utilization range "A" in accordance with ARI Std. 110.

Entering Air Temperature Limits			
Wet Bulb Temp. °C/°F		Dry Bulb Temp. °C/°F	
Min.	Max.	Min.	Max.
14/57	22/72	18/65	35/95

## AIRFLOW DATA\*

MODEL	BLOWER MOTOR SPEED	240 VOLT - 50 HZ									
		CFM OR M <sup>3</sup> /H @ EXTERNAL STATIC PRESSURE - IWG OR Pa									
		0.10	25	0.20	50	0.30	75	0.40	100	0.50	125
		CFM	M <sup>3</sup> /H	CFM	M <sup>3</sup> /H	CFM	M <sup>3</sup> /H	CFM	M <sup>3</sup> /H	CFM	M <sup>3</sup> /H
F2RP024N93	High	950	1615	910	1547	865	1471	835	1420	775	1318
	Med.	845	1437	815	1386	785	1335	745	1267	705	1199
	Low	650	1105	630	1071	605	1029	575	978	540	918
F2RP036N93	High	-	-	1310	2227	1250	2125	1175	1998	1120	1904
	Med	1200	2040	1150	1955	1100	1870	1040	1768	985	1675
	Low	1060	1802	1015	1726	970	1649	925	1573	860	1462
F2RP048N93	High	1855	3154	1795	3052	1730	2941	1670	2839	1605	2729
	Med	1685	2865	1630	2771	1575	2675	1520	2584	1470	2499
	Low	1465	2491	1435	2440	1405	2389	1370	2329	1335	2270
F2RP060N93	High	2285	3885	2195	3732	2105	3579	2015	3426	1920	3264
	Med	2125	3613	2020	3434	1910	3247	1805	3069	1705	2899
	Low	1655	2814	1605	2729	1550	2635	1500	2550	1450	2465

\* INCLUDES RETURN AIR FILTER AND LARGEST ELECTRIC HEATER.

MODEL	BLOWER MOTOR SPEED	220 VOLT - 50 HZ									
		CFM OR M <sup>3</sup> /H @ EXTERNAL STATIC PRESSURE - IWG OR Pa									
		0.10	25	0.20	50	0.30	75	0.40	100	0.50	125
		CFM	M <sup>3</sup> /H	CFM	M <sup>3</sup> /H	CFM	M <sup>3</sup> /H	CFM	M <sup>3</sup> /H	CFM	M <sup>3</sup> /H
F2RP024N93	High	855	1454	819	1392	779	1324	752	1278	698	1187
	Med.	760	1292	733	1246	706	1200	670	1139	634	1078
	Low	585	994.5	567	937	545	927	518	881	486	826
F2RP036N93	High	1235	2100	1179	2004	1125	1913	1058	1799	1008	1714
	Med	1080	1836	1035	1760	990	1683	936	1591	887	1508
	Low	954	1622	914	1554	873	1484	833	1416	774	1319
F2RP048N93	High	1670	2839	1616	2747	1557	2647	1503	2555	1445	2457
	Med	1517	2579	1467	2494	1418	2411	1368	2326	1323	2250
	Low	1319	2242	1292	2196	1265	2151	1233	2096	1202	2043
F2RP060N93	High	2057	3497	1976	3359	1895	3222	1814	3184	1728	2938
	Med	1913	3252	1818	3091	1719	2922	1625	2763	1535	2610
	Low	1490	2533	1445	2457	1395	2372	1350	2295	1305	2219

\* INCLUDES RETURN AIR FILTER AND LARGEST ELECTRIC HEATER.

## APPLICATION FACTORS - Rated CFM vs. Actual CFM

% OF RATED AIR FLOW	80 %	90 %	RATED CFM	110 %	120 %
CAPACITY FACTOR	0.96	0.98	1.00	1.02	1.03

## PHYSICAL AND ELECTRICAL DATA

MODEL		F2RP024N93	F2RP036N93	F2RP048N93	F2RP060N93
BLOWER - DIAMETER X WIDTH, MM (IN.)		254 x 152 (10 x 6)	254 x 203 (10 x 8)	279 x 254 (11 x 10)	279 x 254 (11 x 10)
MOTOR	KW (HP)	0.19 (1/4)	0.37 (1/2)	0.37 (1/2)	0.56 (3/4)
	NOMINAL RPM	1075	1350	1350	1065
VOLTAGE		220/240 (198 MIN - 250 MAX)			
AMPS	FULL LOAD	2.1	2.3	2.4	5.7
	LOCKED ROTOR	5.4	5.4	4.9	7.7
FILTER <sup>1</sup>	TYPE	DISPOSABLE or PERMANENT			
	SIZE	16 x 20 x 1	20 x 21 x 1	22 x 21 x 1	22 x 21 x 1
SHIPPING / OPERATING WEIGHT Kg (lbs.)		42 / 44 (93 / 98)	49 / 52 (109 / 115)	64 / 67 (142 / 148)	68 / 70 (149 / 155)

<sup>1</sup> Field Supplied

## ELECTRICAL DATA - Cooling Only with No Heat Power Kit (1 & 3 Ø)

MODEL	MINIMUM CIRCUIT AMPACITY		MAXIMUM O.C.P.D.	MINIMUM WIRE SIZE A.W.G.
	220V	240V		
F2RP024N93	2.9	2.6	15	14
F2RP036N93	3.1	2.9	15	14
F2RP048N93	3.3	3.0	15	14
F2RP060N93	7.8	7.1	15	14

## ELECTRICAL DATA - 1 Ø - 220/240-1-50

Model	Heater Model	MAX. STATIC & MIN. CFM		Total Heat				KW Staging					
				KW		MBH		W1 Only		W2 Only		W1 + W2	
		Static	Tap	220V	240V	220V	240V	220V	240V	220V	240V	220V	240V
F2RP024N93	2HK*6500506B	0.5	LO	4.2	5.0	14.3	17.1	4.2	5.0	4.2	5.0	4.2	5.0
	2HK*6500806B	0.5	LO	6.3	7.5	21.5	25.6	4.2	5.0	6.3	7.5	6.3	7.5
	2HK*6501006B	0.5	LO	8.4	10.0	28.7	34.1	4.2	5.0	8.4	10.0	8.4	10.0
F2RP036N93	2HK*6500506B	0.5	LO	4.2	5.0	14.3	17.1	4.2	5.0	4.2	5.0	5.0	5.0
	2HK*6500806B	0.5	LO	6.3	7.5	21.5	25.6	4.2	5.0	6.3	7.5	6.3	7.5
	2HK*6501006B	0.5	LO	8.4	10.0	28.7	34.1	4.2	5.0	8.4	10.0	8.4	10.0
	2HK16501506B	0.5	MED	12.6	15.0	43.0	51.2	4.2	5.0	8.4	10.0	12.6	15.0
	2HK16501906B	0.5	HI	14.8	17.6	50.5	60.1	3.2	3.8	11.6	13.8	14.8	17.6
F2RP048N93	2HK*6500506B	0.5	LO	4.2	5.0	14.3	17.1	4.2	5.0	4.2	5.0	4.2	5.0
	2HK*6500806B	0.5	LO	6.3	7.5	21.5	25.6	4.2	5.0	6.3	7.5	6.3	7.5
	2HK*6501006B	0.5	LO	8.4	10.0	28.7	34.1	4.2	5.0	8.4	10.0	8.4	10.0
	2HK16501506B	0.5	LO	12.6	15.0	43.0	51.2	4.2	5.0	8.4	10.0	12.6	15.0
	2HK16502006B	0.5	LO	16.8	20.0	57.3	68.3	4.2	5.0	8.4	10.0	16.8	20.0
	2HK16502506B	0.5	LO	21.0	25.0	71.7	85.3	4.2	5.0	12.6	15.0	21.0	25.0
F2RP060N93	2HK*6500506B	0.5	LO	4.2	5.0	14.3	17.1	4.2	5.0	4.2	5.0	4.2	5.0
	2HK*6500806B	0.5	LO	6.3	7.5	21.5	25.6	4.2	5.0	6.3	7.5	6.3	7.5
	2HK*6501006B	0.5	LO	8.4	10.0	28.7	34.1	4.2	5.0	8.4	10.0	8.4	10.0
	2HK16501506B	0.5	LO	12.6	15.0	43.0	51.2	4.2	5.0	8.4	10.0	12.6	15.0
	2HK16502006B	0.5	LO	16.8	20.0	57.3	68.3	4.2	5.0	8.4	10.0	16.8	20.0
	2HK16502506B	0.5	LO	21.0	25.0	71.7	85.3	4.2	5.0	12.6	15.0	21.0	25.0

\* 0 or 1 as follows: 0 = No Breaker, 1 = Breaker.

## ELECTRICAL DATA - 1 Ø (SINGLE SOURCE POWER SUPPLY) - COPPER WIRE

Model	Heater Model*	Heater Amps 240V	Field Wiring					
			Min. Circuit Ampacity		Max. O.C.P. <sup>2</sup> Amps/Type		75°C Wire Size - AWG	
			220V	240V	220V	240V	220V	240V
F2RP024N93	2HK*6500506B	20.8	26.7	28.7	30	30	10	10
	2HK*6500806B	31.3	38.7	41.7	40	45	8	8
	2HK*6501006B	41.7	50.6	54.7	60	60	6	6
F2RP036N93	2HK*6500506B	20.8	27.0	28.9	30	30	10	10
	2HK*6500806B	31.3	31.3	41.9	40	45	8	8
	2HK*6501006B	41.7	50.9	55.0	60	60	6	6
	2HK16501506B	62.5	74.7	81.0	80	90	4	3
	2HK16501906B	73.3	87.2	94.5	90	100	3	3
F2RP048N93	2HK*6500506B	20.8	27.1	29.0	30	30	10	10
	2HK*6500806B	31.3	39.0	42.1	40	45	8	8
	2HK*6501006B	41.7	51.0	55.1	60	60	6	6
	2HK16501506B	62.5	74.8	81.1	80	90	4	3
	2HK16502006B	83.3	98.7	107.2	100	110	3	2
	2HK16502506B	104.2	122.6	133.2	125	150	1	1/0
F2RP060N93	2HK*6500506B	20.8	31.6	33.2	35	35	8	8
	2HK*6500806B	31.3	43.5	46.2	45	50	8	8
	2HK*6501006B	41.7	55.5	59.2	60	60	6	6
	2HK16501506B	62.5	79.3	85.3	80	90	4	3
	2HK16502006B	83.3	103.2	111.3	110	215	2	1
	2HK16502506B	104.2	127.1	137.3	150	150	1/0	1/0

## ELECTRICAL DATA - 1 Ø (MULTI-SOURCE POWER SUPPLY) - COPPER WIRE

Model	Heater Model	Min. Circuit Ampacity			Max. Time Delay Fuse			75°C Wire Size - AWG		
		Circuit			Circuit			Circuit		
		1st	2nd	3rd	1st	2nd	3rd	1st	2nd	3rd
F2RP036N93	2HK16501506B	27.0/28.9	47.7/52.1	-	30/30	50/60	-	10/10	8/6	-
	2HK16501906B	38.9/41.9	48.3/52.6	-	40/45	50/60	-	8/8	8/6	-
F2RP048N93	2HK16501506B	27.1/29.0	47.7/52.1	-	30/35	50/60	-	10/10	8/6	-
	2HK16502006B	51.0/55.1	47.7/52.1	-	60/60	50/60	-	6/6	8/6	-
	2HK16502506B	27.1/29.0	47.7/52.1	47.7/52.1	30/30	50/60	50/60	10/10	8/6	8/6

## ELECTRICAL DATA - 3 Ø - 220/240-3-50

Model	Heater Model	Total Heat <sup>1</sup> KW		Total Heat <sup>1</sup>				KW Staging**					
		220V	240V	KW		MBH		W1 Only		W2 Only		W1 + W2	
				220V	240V	220V	240V	220V	240V	220V	240V	220V	240V
F2RP024N93	2HK06501025B	0.5	LO	8.4	10.0	28.7	34.1	4.2	5.0	8.4	10.0	8.4	10.0
F2RP036N93	2HK06501025B	0.5	LO	8.4	10.0	28.7	34.1	4.2	5.0	8.4	10.0	8.4	10.0
	2HK06501525B	0.5	MED	12.6	15.0	43.0	51.2	4.2	5.0	8.4	10.0	12.6	15.0
F2RP048N93	2HK06501025B	0.5	LO	8.4	10.0	28.7	34.1	4.2	5.0	8.4	10.0	8.4	10.0
	2HK06501525B	0.5	LO	12.6	15.0	43.0	51.2	4.2	5.0	8.4	10.0	12.6	15.0
F2RP060N93	2HK06501025B	0.5	LO	8.4	10.0	28.7	34.1	4.2	5.0	8.4	10.0	8.4	10.0
	2HK06501525B	0.5	LO	12.6	15.0	43.0	51.2	4.2	5.0	8.4	10.0	12.6	15.0

## ELECTRICAL DATA - 3 Ø (SINGLE SOURCE POWER SUPPLY) - COPPER WIRE

Model	Heater Model	Field Wiring					
		Min. Circuit Ampacity		Max. O.C.P. <sup>2</sup> Amps/Type		75°C Wire Size - AWG	
		220V	240V	220V	240V	220V	240V
F2RP024N93	2HK06501025B	43.8	47.4	45	50	8	8
F2RP036N93	2HK06501025B	44.1	47.6	45	50	8	8
	2HK06501525B	44.1	47.6	45	50	8	8
F2RP048N93	2HK06501025B	44.2	47.7	45	50	8	8
	2HK06501525B	44.2	47.7	45	50	8	8
F2RP060N93	2HK06501025B	48.2	51.4	50	60	8	6
	2HK06501525B	48.2	51.4	50	60	8	6

1 See Conversion Table page 6.

<sup>2</sup> O.C.P. = Over-Current Protection\*\* If first stage heat or 66 is connected to W<sub>1</sub>, otherwise refer to Table at bottom of page 6.

## WIRING DIAGRAMS - COOLING MODELS

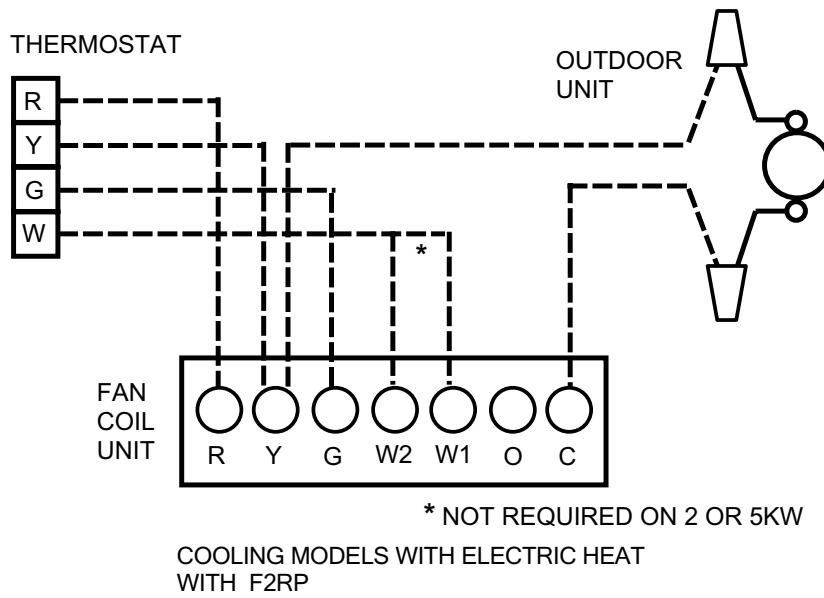
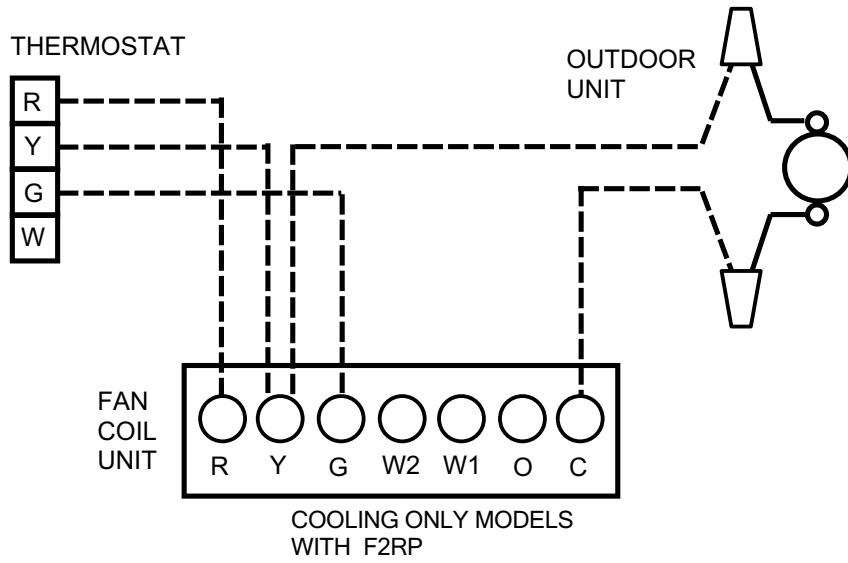

# WIRING DIAGRAMS - HEAT PUMP MODELS with F2RP

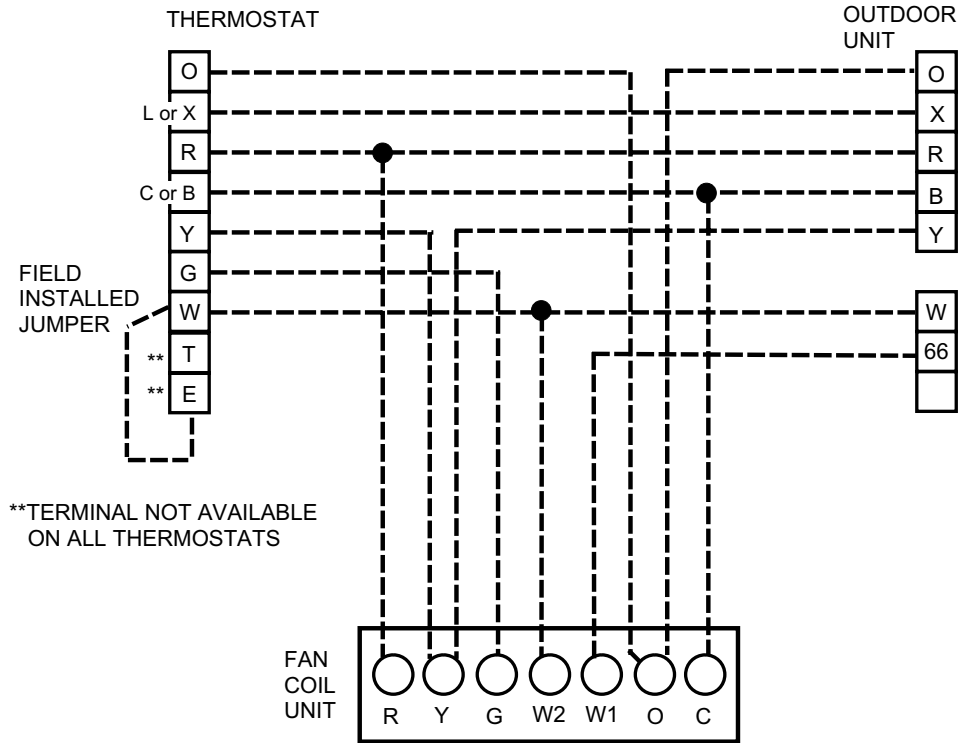

# TYPICAL INSTALLATION

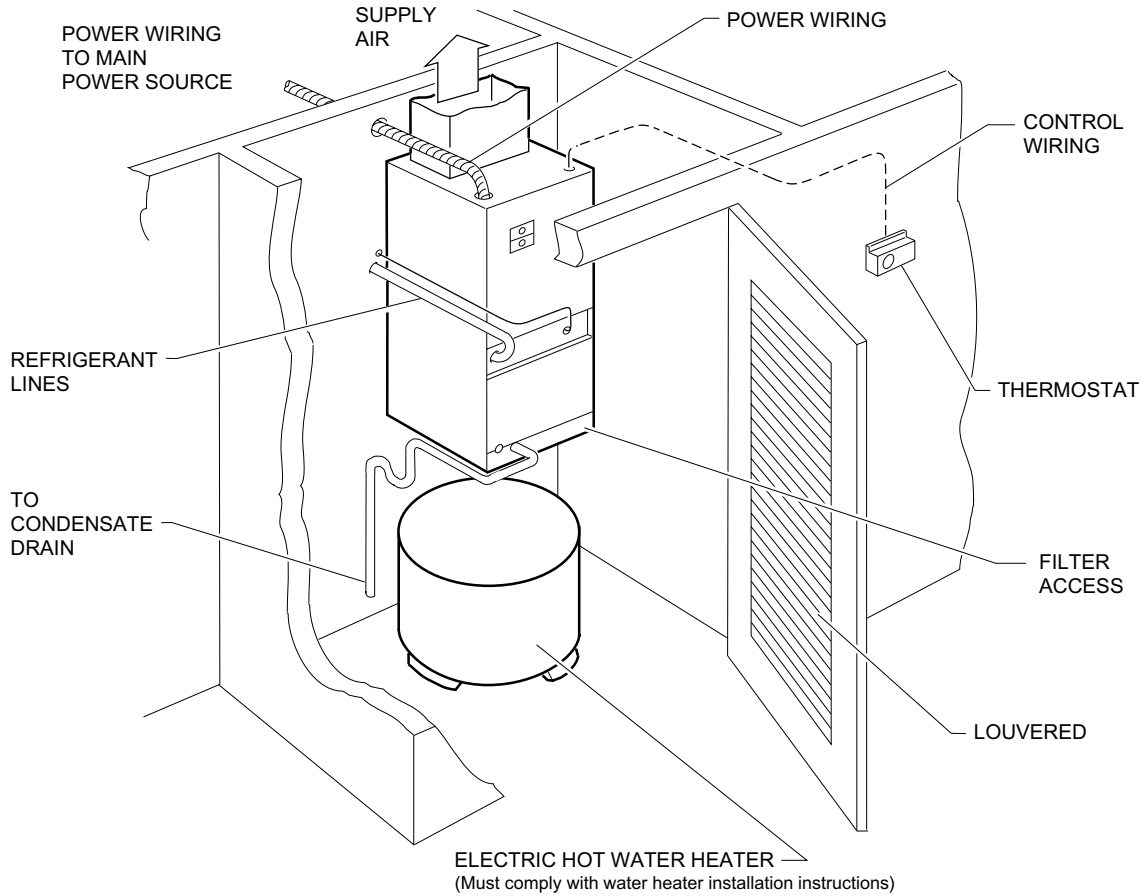

# TYPICAL APPLICATIONS

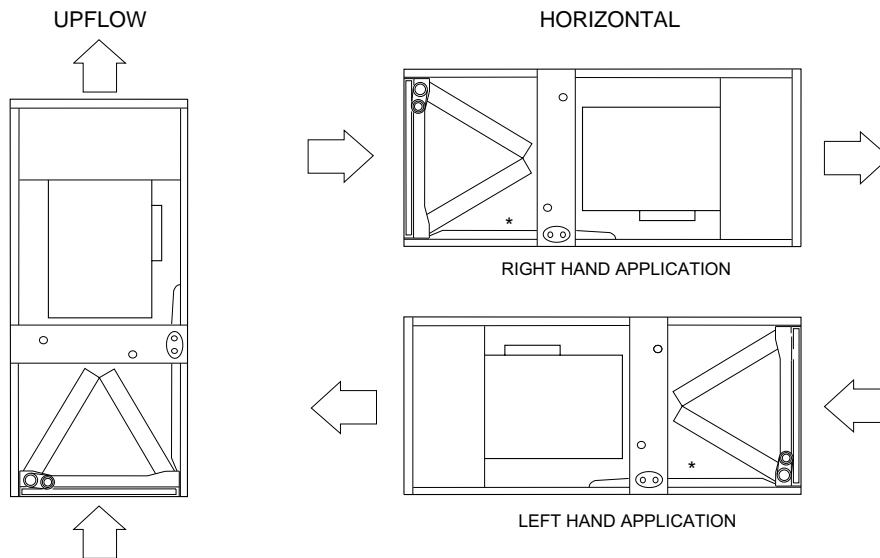

\* Requires Horizontal Pan Accessory



Heating and Air Conditioning

Unitary Products Group  
 5005 York Drive, Norman, Oklahoma 73069  
 Subject to change without notice. Printed in U.S.A.  
 Copyright © by York International Corporation 1999. All Rights Reserved.



36USC380  
 Proud Sponsor  
 of the 2000  
 U.S. Olympic Team

Code: EBI

535.02-TG4YI (600)  
 Supersedes: 535.02-TG4YI (899)